

LASER SCAN MICROMETER

NON-CONTACT MEASURING SYSTEM COMBINES
HIGH-RATE SCANNING WITH HIGHLY ACCURATE MEASUREMENT



Laser Scan Micrometers

High scanning rate (3200 scans/sec) and high accuracy, non-contact measuring systems. The LSM features a very high scanning rate which allows inspection of small workpieces even if they are fragile, at a high temperature, in motion or vibrating.



Features

0.005mm-diameter ultra-fine wires to 160mm-diameter cylinders can be measured: Seamless measurement range models

A rich assortment of models for diverse measuring applications. The LSM-500S can measure ultra-fine wires as thin as 0.005mm in diameter to a resolution of 0.00001mm, and the LSM-516S can measure cylindrical workpieces with a diameter as large as 160mm. The LSM-9506 bench-top model combines a display section and measurement section all in one unit.

Ultra-high scanning rate 3200 scans/sec

The incorporation of a sixteen-face polygonal mirror and a high-precision motor now makes scanning at 3200 scans per second possible. This formidable capability is ideal, for example, for taking measurements on high-speed production lines or on vibrating workpieces.

Certified accuracy over the entire measurement range

The specified high accuracy over the entire measurement range is certified by the "Traceability System to the International Standard" which Mitutoyo, as a leading manufacturer of precision

measurement tools and instruments, has established within its business practises.

Improved resistance to IP64-level environments

The measuring unit has been extensively developed to resist rough measurement environments. As a result, for example, it can operate at an ambient temperature of 45°C. (IP64-level resistance is not guaranteed for the display unit and the LSM-9506.)

DIN-size compact panel-mounted display unit (LSM-5200)

The LSM-5200 display unit is a compact DIN size, allowing it to be mounted in a panel so as to be suitable for mounting in a rack, etc., for use on production lines.

Standard I/O output, analog output and RS-232C output interfaces

The LSM-5200/6200/6900 has a standard I/O and analog output interface to connect it to an operation controller or PLC used on a production line. Also, every model has a standard RS-232C interface for connection to personal computers or printers.

Principle

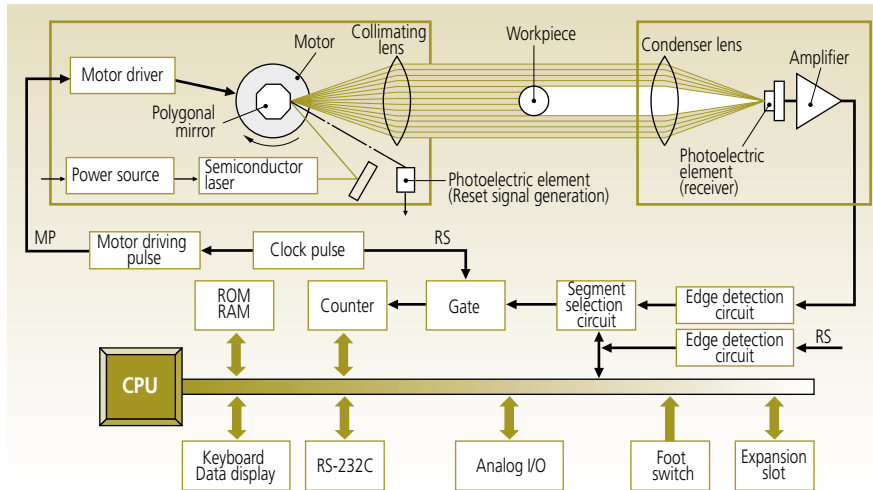

A laser beam is directed at a polygonal mirror rotating at high speed in exact synchronism with highly stable pulses from the system clock. The reflected beam is rotating clockwise as it sweeps across the input surface of a collimating lens but changes direction to be always horizontal after the lens' exit surface as it moves, or scans, downward. This horizontal beam enters the measuring space and, with no workpiece present, reaches a receiver via a condensing lens to produce an output signal. When a simple workpiece (a cylinder, for example) is put into the measuring space the beam will be interrupted for a time during its sweep and this time, as indicated by clock pulses occurring while the receiver signal is absent, is proportional to the workpiece dimension in the downward direction. Each transition between the receiver detecting the beam and then not detecting the beam, or vice versa, is called an 'edge' and marks the start and/or end of measuring sections called 'segments', so that the differences in position of these edges define the length of each segment. The edges and segments generated by a workpiece are numbered sequentially by the instrument and are used when writing programs to extract the required dimensional data.

Index

	Pages
Applications	4
All Models of Laser Scan Micrometer	6
Measuring Unit	
LSM-902/6900 Ultra-High Accuracy Measuring Unit	8
LSM-500S Ultra-Fine Wire Measuring Unit	10
LSM-501S Fine Wire Measuring Unit	12
LSM-503S Standard Measuring Unit	14
LSM-506S Wide Range Measuring Unit	16
LSM-512S Ultra-Wide Range Measuring Unit	18
LSM-516S Ultra-Wide Range Measuring Unit	20
LSM-9506 Bench-top Type with Display Unit	22
Optional accessories for Measuring Unit	
Calibration Gage Sets	23
Extension Signal Cables	23
Extension Relay Cables	23
Workstage	23
Wire Guiding Pulleys	23
Air-screen System	23
Adjustable Workstages	24

	Pages
Display Unit	
LSM-5200 Compact (Panel-mount) Type Display Unit	28
LSM-6200 Multi-function Type Display Unit	29
LSM-5200/6200/6900/9506 Functions	30
LSM-5200/6200/6900/9506 Data I/O Specifications	32
Optional accessories for Display Unit	
LSMPAK	34
BCD Interface Unit	34
Digimatic Code-out Unit	35
Dual-type Add-on Unit	35
2nd I/O-Analog Interface Unit	36
BCD/2nd I/O-Analog Interface Cable	37
Thermal Printer	37
Footswitch	37
Glossary	38
Precautions	
Observe the following precautions	39
Re-assembly after removal from the base	39

Applications

On-line measurement of glass fiber or fine wire diameter

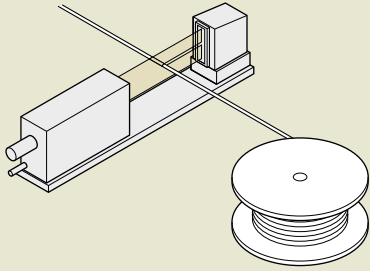

Measurement of outer diameter of cylinder

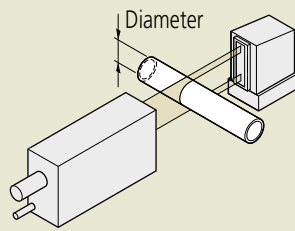

Measurement of outer diameter and roundness of cylinder

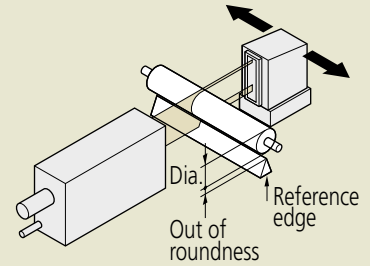

X- and Y-axis measurement of electric cables and fibers

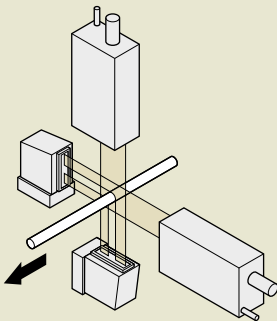

Measurement of thickness of film and sheet

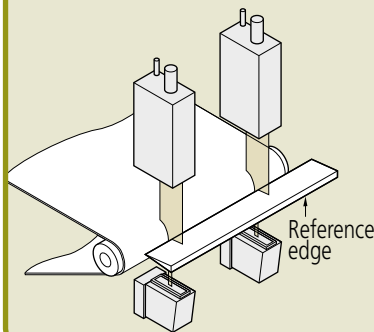

Measurement of spacing of IC chip leads

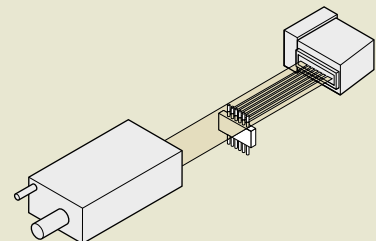

Measurement of film sheet thickness

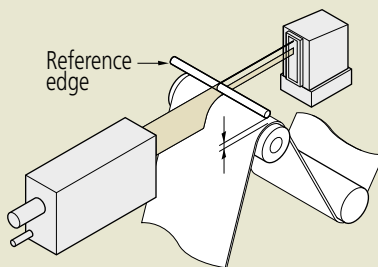

Measurement of laser disk and magnetic disk head movement

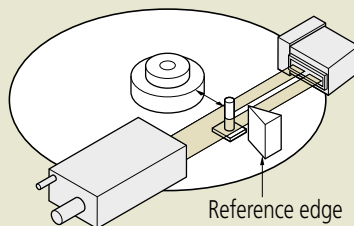

Measurement of gap between rollers

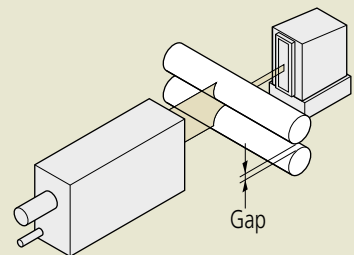

Measurement of tape width

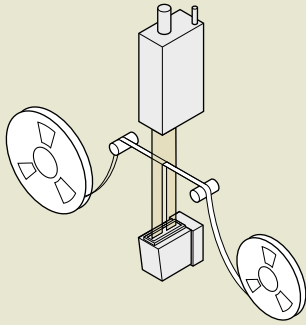

Measurement of outer diameter of optical connector and ferrule

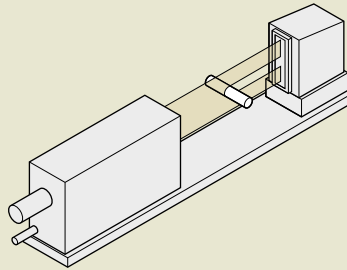

Measurement of form

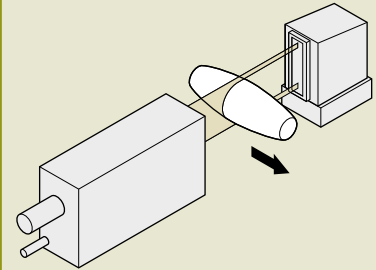

Optimal for Inspecting the Outside Diameter of Pin Gages or Plug Gages

The use of world-class laser scan micrometer LSM-902/6900 along with an adjustable workstage allows high-accuracy measurement inspection of the outside diameter of pin gages or plug gages. This LSM is also capable of data output to an external device such as a personal computer from the display unit.

(Measurement data can be stored easily in cells on EXCEL by using the Mitutoyo input tool.)

■ Major Specifications

Measuring range: 0.1 mm to 25.0 mm in diameter

Resolution: 0.01 μm

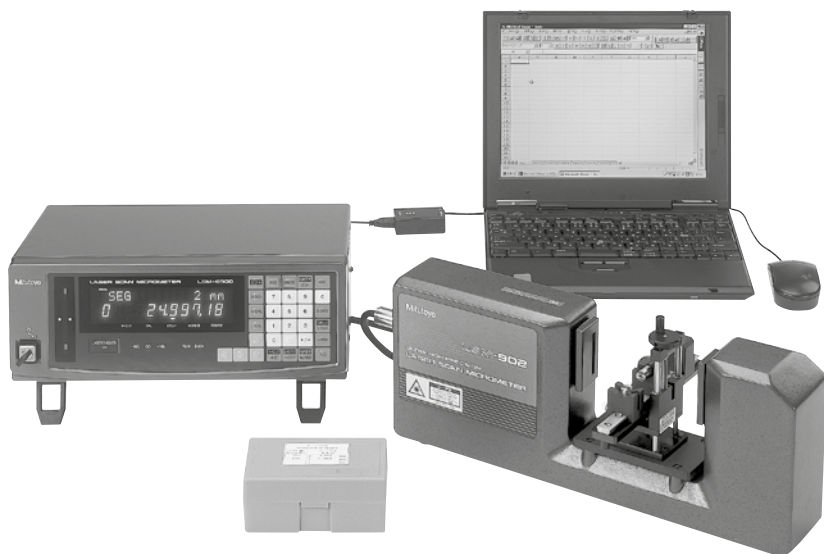
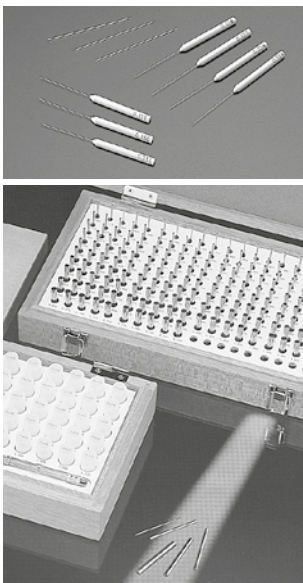

Linearity: $\pm 0.5 \mu\text{m}$

Repeatability: $\pm 0.05 \mu\text{m}$



All models of Laser Scan Micrometer

Measuring Units

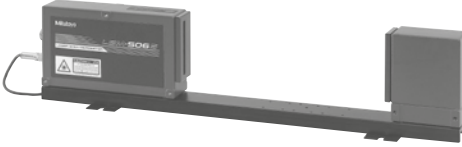
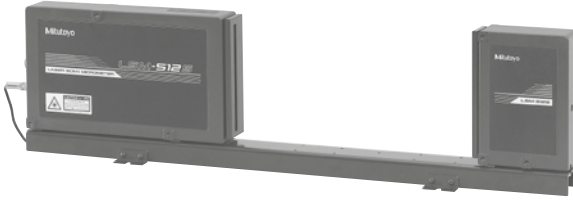
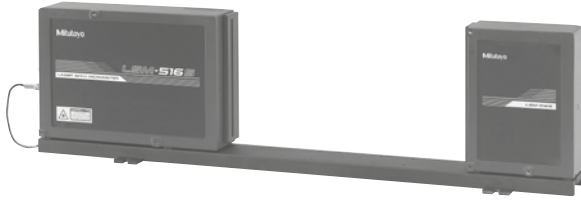
Measuring range	Model	Refer to...
0.005 - 2mm (.0002" - .08")	LSM-500S 	Page 10
0.05 - 10mm (.002" - .4") FDA Class II	LSM-501S 	Page 12
0.3 - 30mm (.012" - 1.18")	LSM-503S 	Page 14
1 - 60mm (.04" - 2.36")	LSM-506S 	Page 16
1 - 120mm (.04" - 4.72")	LSM-512S 	Page 18
1 - 160mm (.04" - 6.30")	LSM-516S 	Page 20

Measuring Unit (Factory-set package)

Measuring range	Model	Refer to...
0.1 - 25mm (.004" - 1.0")	LSM-902/6900 	Page 8

Measuring Unit with integrated display

Measuring range	Model	Refer to...
0.5 - 60mm (.02" - 2.36")	LSM-9506 Measuring unit / integrated-display model for bench-top use only 	Pages 22

Display Units

Type	Model	Refer to...
Multi-function (Power Supply 100V - 240V AC)	LSM-6200 	Page 29
Compact (Power Supply +24V DC)	LSM-5200 	Pages 28

LSM-902/6900

Ultra-High Accuracy Measuring Unit

- > Suitable for pin and plug gage measurements.
- > Wide measuring range of \varnothing 0.1 mm to \varnothing 25 mm
- > Provides ultra-high accuracy with a linearity of $\pm 0.5 \mu\text{m}$ over the entire measurement range and $\pm(0.3+0.1\Delta D) \mu\text{m}$ in the narrow range.
- > Ultra-high repeatability of $\pm 0.05 \mu\text{m}$

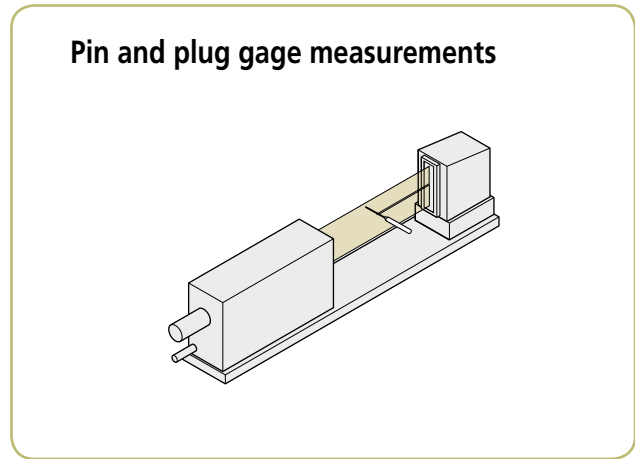
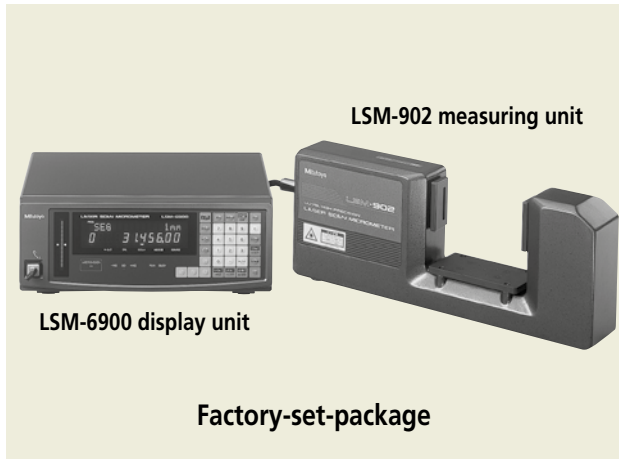

Specifications

Model	LSM-902/6900		
(Order no. suffix denotes the AC power cord type equipped.)	120V AC	544-495A	544-496A
	220/230V AC	544-495D	544-496D
	240V AC	544-495E	544-496E

<Display unit>		
Acceptable standard of laser	IEC (FDA: 544-495A)	IEC (FDA: 544-496A)
Measuring range	0.1 - 25 mm (.004" - 1.0")	
Resolution (selectable)	0.00001 - 0.01 mm (.000001" - .0005")	
Repeatability*1	$\pm 0.05 \mu\text{m}$ ($\pm 1.9 \mu\text{inch}$)	
Linearity at 20°C*2	Entire range	$\pm 0.5 \mu\text{m}$ ($\pm 20 \mu\text{inch}$)
	Narrow range	$\pm(0.3+0.1\Delta D) \mu\text{m}$ *5
Positional error*3	$\pm 0.5 \mu\text{m}$ ($\pm 20 \mu\text{inch}$)	
Measuring region*4	3x25 mm (.12"x.98")	
Scanning rate	800 scans/s	
Laser wavelength	650 nm, Visible*6	
Laser scanning speed	56 m/s (2200"/s)	
Operating temperature	0°C - 40°C	
Operating humidity	35 - 85% RH (with no condensation)	
Mass	Measuring unit: 6.0kg (13.2lbs.), Signal cable: 0.5kg (1.1lbs.)	

<Measuring unit>

Type	mm	inch/mm
Display	16-digit fluorescent tube (for measurement) & 11-digit fluorescent tube (sub display)	
Segment designation	Seg.1 to Seg.7 (Seg.1 - Seg.3 for transparent objects)	
Edge designation	1 to 255 edges can be detected	
Averaging times	Arithmetical average: per 1 to 2048, moving average: per 32 to 2048	
GO/ \pm NG judgment	Nominal value \pm tolerance setting, upper & lower limits setting, multi-limit setting	
Measurement mode	Waiting, single measurement, continuous measurement	
Statistical calculation	Maximum measurement (MAX), minimum measurement (MIN), mean, range (MAX-MIN), standard deviation (σ)	
Power supply	100 - 240V AC $\pm 10\%$, 50/60Hz, 40VA	
Data output (as standard)	Via RS-232C and I/O-Analog interfaces	
Functions	(See page 16 and 17.)	
Operating temperature	0°C - 40°C	
Operating humidity	35 - 85% RH (with no condensation)	
Mass	5kg (11lbs.)	

*1: Determined by the value for $\pm 2\sigma$ at the measurement of $\varnothing 25\text{mm}$ workpiece with 1.28sec. interval (1024-time average).

*2: At the center of the measuring region.

*3: An error due to workpiece shift either in the optical axis direction or in the scanning direction.

*4: The area given by "measuring range on the optical axis" x "measuring range in the scanning direction".

*5: ΔD =Difference in diameter between the master gage and workpiece in mm.

*6: FDA Class II/IEC Class 2 semiconductor laser for scanning (Maximum power: 1.5mW)

LSM-500S

Ultra-Fine Wire Measuring Unit

- > Permits measurements starting from $\phi 5\mu\text{m}$
- > Provides ultra-high accuracy with a linearity of $\pm 0.3\mu\text{m}$ over the entire measurement range (5 μm to 2mm).
- > Ultra-high repeatability of $\pm 0.03\mu\text{m}$

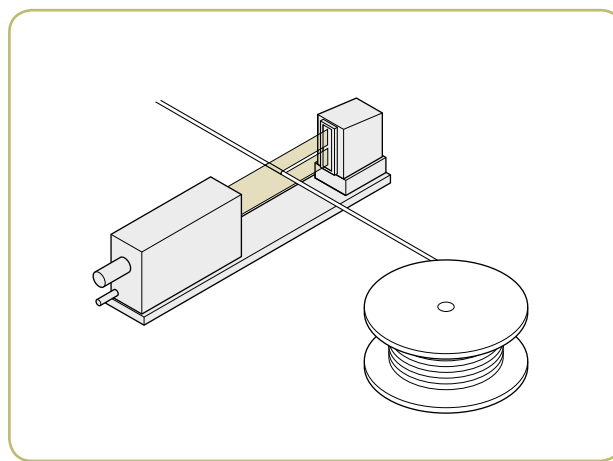

Specifications

Model	LSM-500S
Order No.	544-532
Acceptable standard of laser	IEC, FDA
Measuring range*1	0.005 - 2mm (.0002" - .08")
Resolution (selectable)	0.00001 - 0.01mm (.000001" - .0005")
Repeatability*2	$\pm 0.03\mu\text{m}$ ($\pm 1.1\mu\text{inch}$)
Linearity at 20°C*3	$\pm 0.3\mu\text{m}$ ($\pm 12\mu\text{inch}$)
Positional error*4	$\pm 0.4\mu\text{m}$ ($\pm 16\mu\text{inch}$)
Measuring region*5	1x2mm (.04"x.08")
Scanning rate	3200 scans/s
Laser wavelength	650nm, Visible*6
Laser scanning speed	76m/s (3000"/s)
Operating temperature	0°C - 40°C
Operating humidity	35 - 85% RH (with no condensation)
Water/Dust protection grade	Conforming to IP64*7
Mass	Measuring unit: 1.0kg (2.2lbs.), Signal cable: 0.5kg (1.1lbs.)

*1: If a workpiece is transparent or if the dual-type add-on unit that is an optional accessory for the **LSM-6200** display unit is used, measurement range will be set to between 0.05mm (.002") to 2mm (.08"). In addition, if the edge measurement is selected for 1 to 255 edges and if the automatic workpiece detecting function is on, measuring range will be set to between 0.1mm (.004") to 2mm (.08").

*2: Determined by the value for $\pm 2\sigma$ at the measurement of $\phi 2\text{mm}$ workpiece with 0.32sec. interval (1024-time average).

*3: At the center of the measuring region.

*4: An error due to workpiece shift either in the optical axis direction or in the scanning direction.

*5: The area given by "measuring range on the optical axis" x "measuring range in the scanning direction".

*6: FDA Class II/IEC Class 2 semiconductor laser for scanning (Maximum power: 1.3mW)

*7: The protection level provided for the interior. If the workpiece or glass of the measuring unit window is soiled by water or dust, the unit may malfunction.

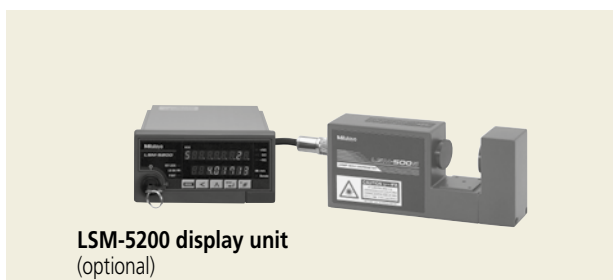
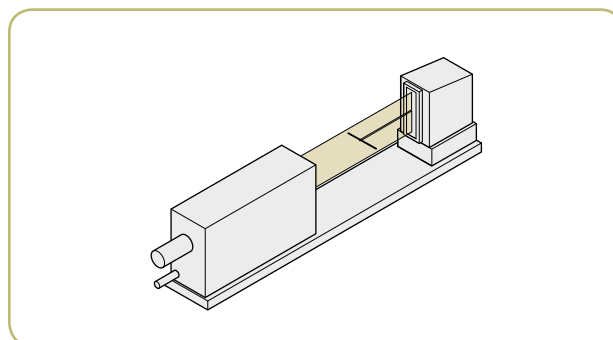

Dimensions

Unit: mm (inch)

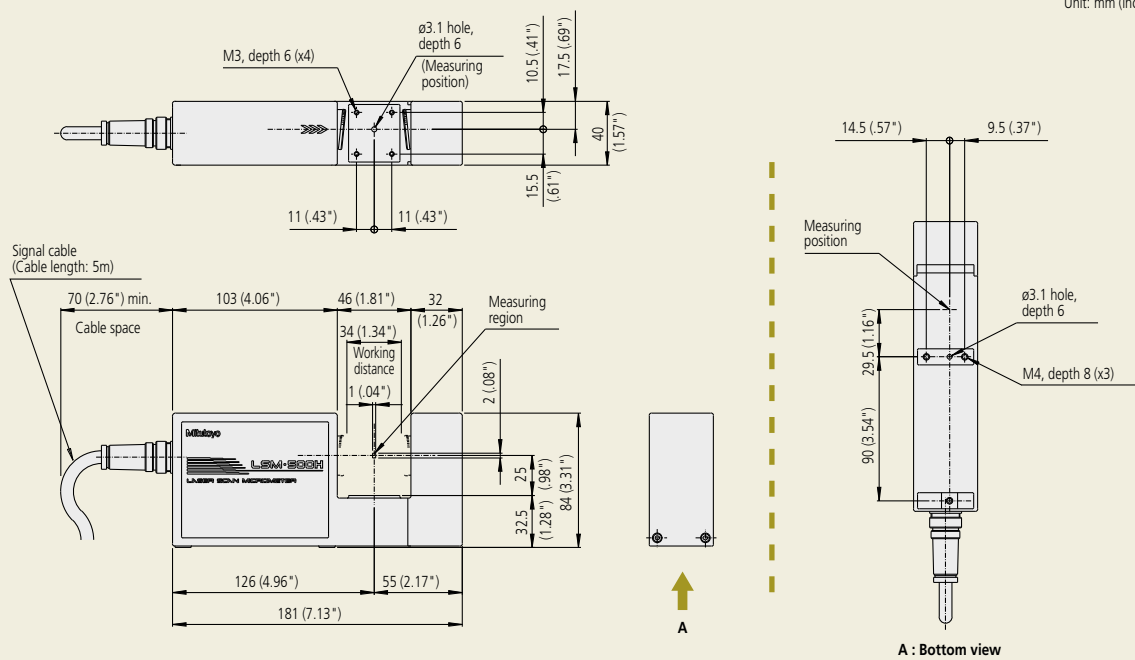

Optional accessories

02AGD110

Calibration gage set (ø0.1mm, ø2.0mm)



02AGD200

Wire guiding pulley

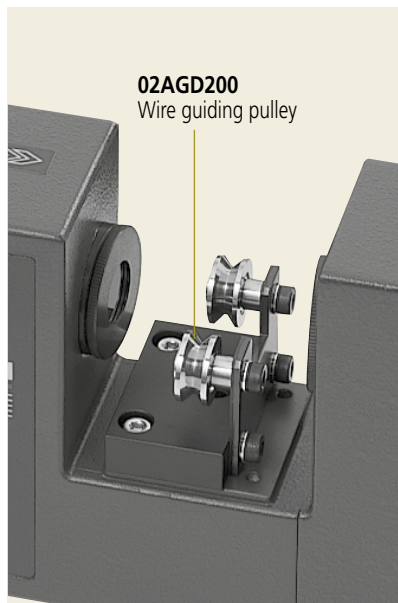

02AGD220

Air-screen covers

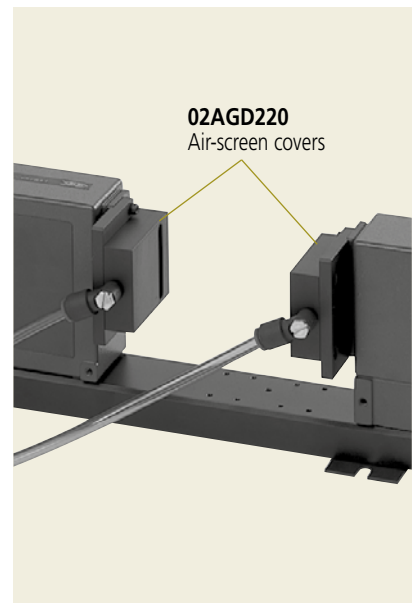

957608

Air cleaner for air-screen covers

02AGN780A

Extension signal cable 5m

02AGN780B

Extension signal cable 10m

02AGN780C

Extension signal cable 15m

LSM-501S

Fine Wire Measuring Unit

- > Provides ultra-high accuracy with a linearity of $\pm 0.5\mu\text{m}$ over the entire measurement range (0.05mm to 10mm) and $\pm(0.3+0.1\Delta D)\mu\text{m}$ in the narrow range.
- > Ultra-high repeatability of $\pm 0.04\mu\text{m}$

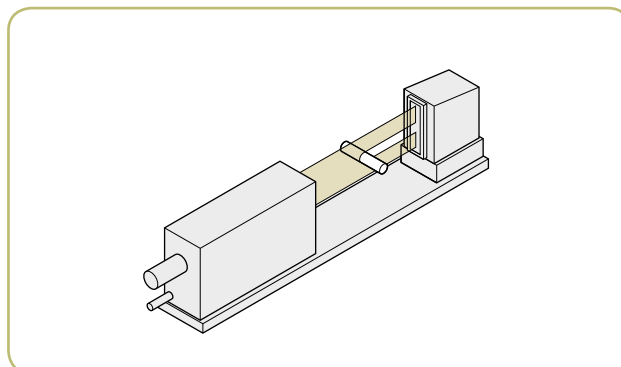
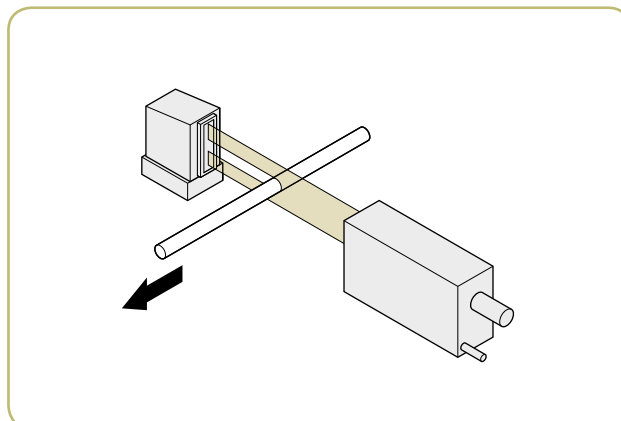

Specifications

Model	LSM-501S
Order No.	544-534
Acceptable standard of laser	IEC, FDA
Measuring range	0.05 - 10mm (.002" - .4")
Resolution (selectable)	0.00001 - 0.01mm (.000001" - .0005")
Repeatability*1	$\pm 0.04\mu\text{m}$ ($\pm 1.5\mu\text{inch}$)
Linearity	Entire range: $\pm 0.5\mu\text{m}$ ($\pm 20\mu\text{inch}$)
at 20°C*2	Narrow range: $\pm(0.3+0.1\Delta D)\mu\text{m}$
Positional error*3	$\pm 0.5\mu\text{m}$ ($\pm 20\mu\text{inch}$)
Measuring region*4	2 x 10mm at $\phi 0.05 - 0.1\text{mm}$ (.08" x .4" at $\phi 0.002" - .004"$) 4 x 10mm at $\phi 0.1 - 10\text{mm}$ (.16" x .4" at $\phi 0.004" - .4"$)
Scanning rate	3200 scans/s
Laser wavelength	650nm, Visible*5
Laser scanning speed	113m/s (4450"/s)
Operating temperature	0°C - 40°C
Operating humidity	35 - 85% RH (with no condensation)
Water/Dust protection grade	Conforming to IP64*6
Mass	Emission unit: 0.7kg (1.54lbs.), Reception unit: 0.4kg (.88lbs.), Base: 0.3kg (.66lbs.), Signal cable: 0.5kg (1.1lbs.)

*1: Determined by the value for $\pm 2\sigma$ at the measurement of $\phi 10\text{mm}$ workpiece with 0.32sec. interval (512-time average).

*2: At the center of the measuring region.

*3: An error due to workpiece shift either in the optical axis direction or in the scanning direction.

*4: The area given by "measuring range on the optical axis" x "measuring range in the scanning direction".

*5: FDA Class II/IEC Class 2 semiconductor laser for scanning (Maximum power: 1.3mW)

*6: The protection level provided for the interior. If the workpiece or glass of the measuring unit window is soiled by water or dust, the unit may malfunction.



Dimensions

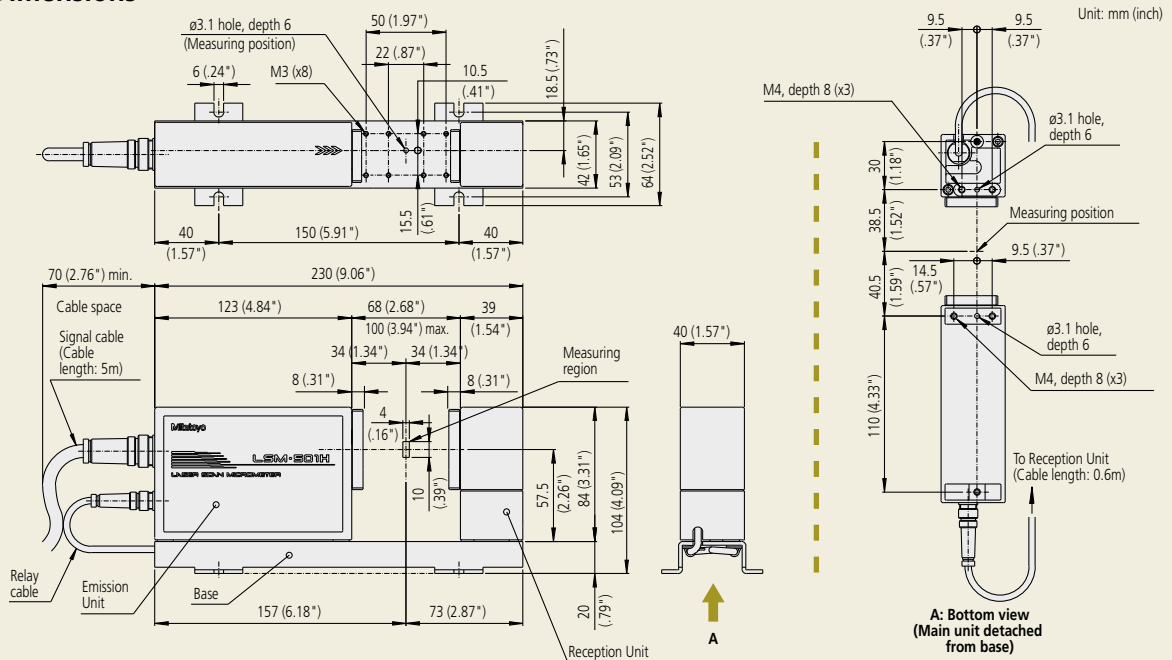

Optional accessories

02AGD120
Calibration gage set (ø0.1 mm, ø10mm)



02AGD210
Wire guiding pulley

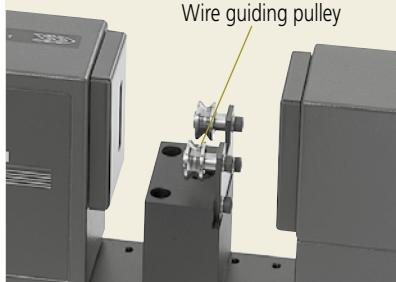

02AGD400
Adjustable workstage

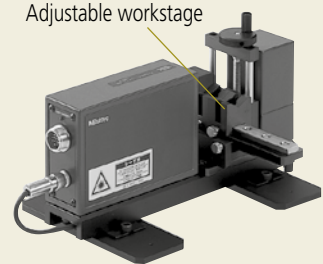

02AGD230
Air-screen covers

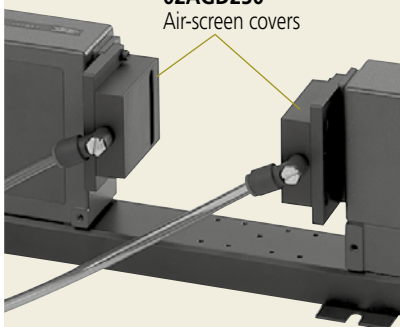

02AGD270
Workstage

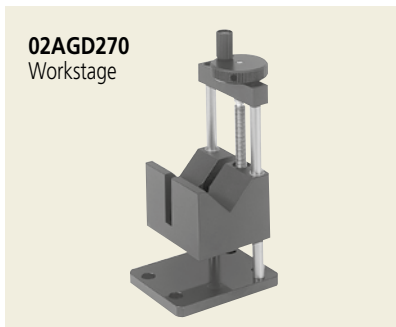

02AGD440 Center support*
02AGD450 Adjustable V-block*
957608 Air cleaner for air-screen cover
02AGC150A Extension relay cable 1m
02AGN780A Extension signal cable 5m
02AGN780B Extension signal cable 10m
02AGN780C Extension signal cable 15m
*Use with an adjustable workstage.

LSM-503S

Standard Measuring Unit

- > General-purpose type with a measurement range of 0.3mm to 30mm.
- > Provides high accuracy with a linearity of $\pm 1.0\mu\text{m}$ over the entire measurement range and $\pm(0.6+0.1\Delta D)\mu\text{m}$ in the narrow range.
- > Excellent repeatability of $\pm 0.1\mu\text{m}$

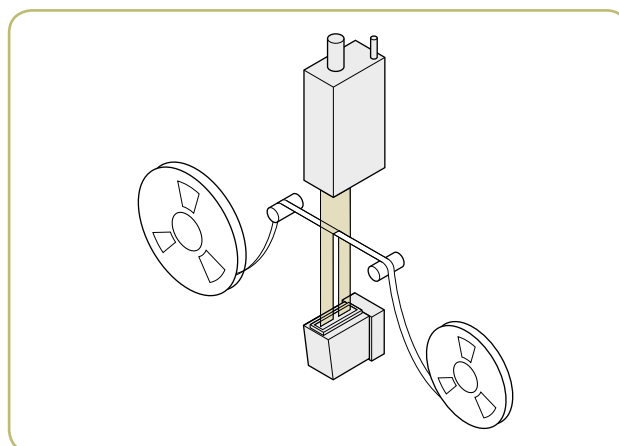
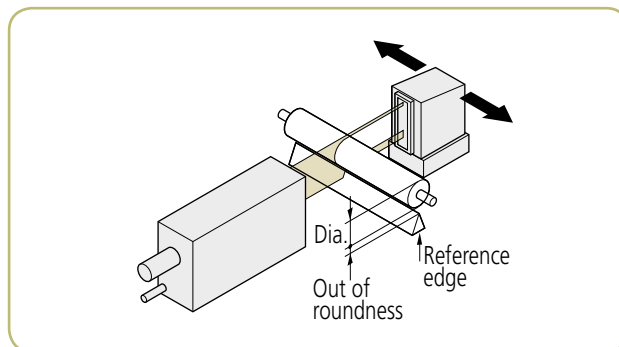
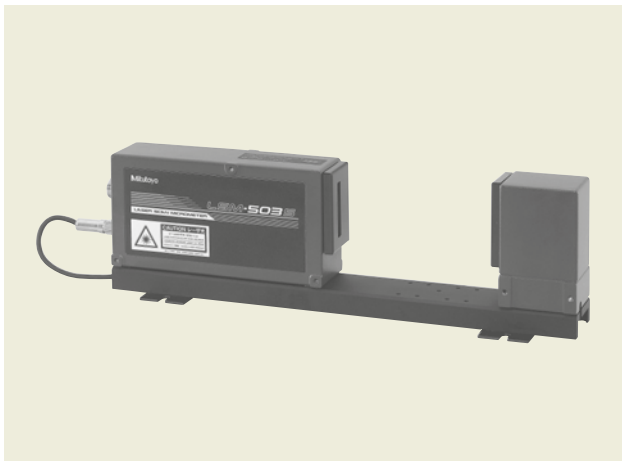

Specifications

Model	LSM-503S				
Order No.	544-536				
Acceptable standard of laser	IEC, FDA				
Measuring range	0.3 - 30mm (.012" - 1.18")				
Resolution (selectable)	0.00002 - 0.1mm (.000001" - .005")				
Repeatability*1	$\pm 0.1\mu\text{m}$ ($\pm 3.9\mu\text{inch}$)				
Linearity at 20°C*2	<table border="1"> <tr> <td>Entire range</td> <td>$\pm 1.0\mu\text{m}$ ($\pm 40\mu\text{inch}$)</td> </tr> <tr> <td>Narrow range</td> <td>$\pm(0.6+0.1\Delta D)\mu\text{m}$</td> </tr> </table>	Entire range	$\pm 1.0\mu\text{m}$ ($\pm 40\mu\text{inch}$)	Narrow range	$\pm(0.6+0.1\Delta D)\mu\text{m}$
Entire range	$\pm 1.0\mu\text{m}$ ($\pm 40\mu\text{inch}$)				
Narrow range	$\pm(0.6+0.1\Delta D)\mu\text{m}$				
Positional error*3	$\pm 1.5\mu\text{m}$ ($\pm 60\mu\text{inch}$)				
Measuring region*4	10 x 30mm (.4" x 1.18")				
Scanning rate	3200 scans/s				
Laser wavelength	650nm, Visible*5				
Laser scanning speed	226m/s (8900"/s)				
Operating temperature	0°C - 40°C				
Operating humidity	35 - 85% RH (with no condensation)				
Water/Dust protection grade	Conforming to IP64*6				
Mass	Emission unit: 1.1kg (2.42lbs.), Reception unit: 0.6kg (1.32lbs.), Base: 0.5kg (1.1lbs.), Signal cable: 0.5kg (1.1lbs.)				

*1: Determined by the value for ± 2 at the measurement of $\varnothing 30\text{mm}$ workpiece with 0.32sec. interval (1024-time average).

*2: At the center of the measuring region.

*3: An error due to workpiece shift either in the optical axis direction or in the scanning direction.

*4: The area given by "measuring range on the optical axis" x "measuring range in the scanning direction".

*5: FDA Class II/IEC Class 2 semiconductor laser for scanning (Maximum power: 1.3mW)

*6: The protection level provided for the interior. If the workpiece or glass of the measuring unit window is soiled by water or dust, the unit may malfunction.

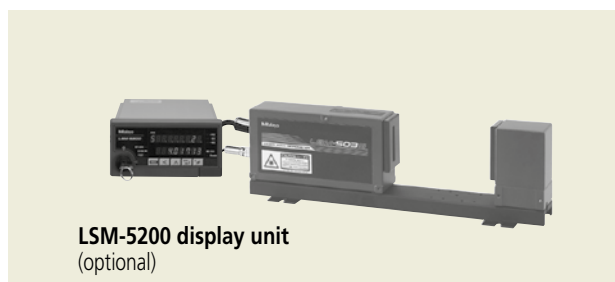
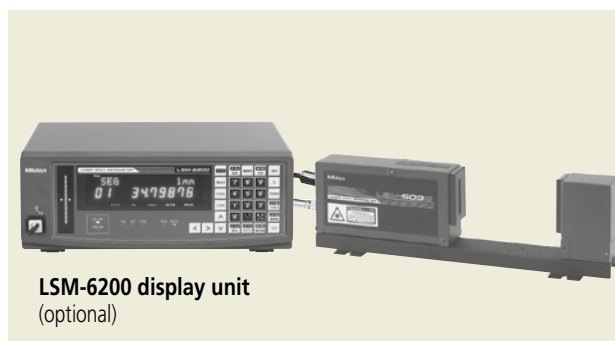

Dimensions

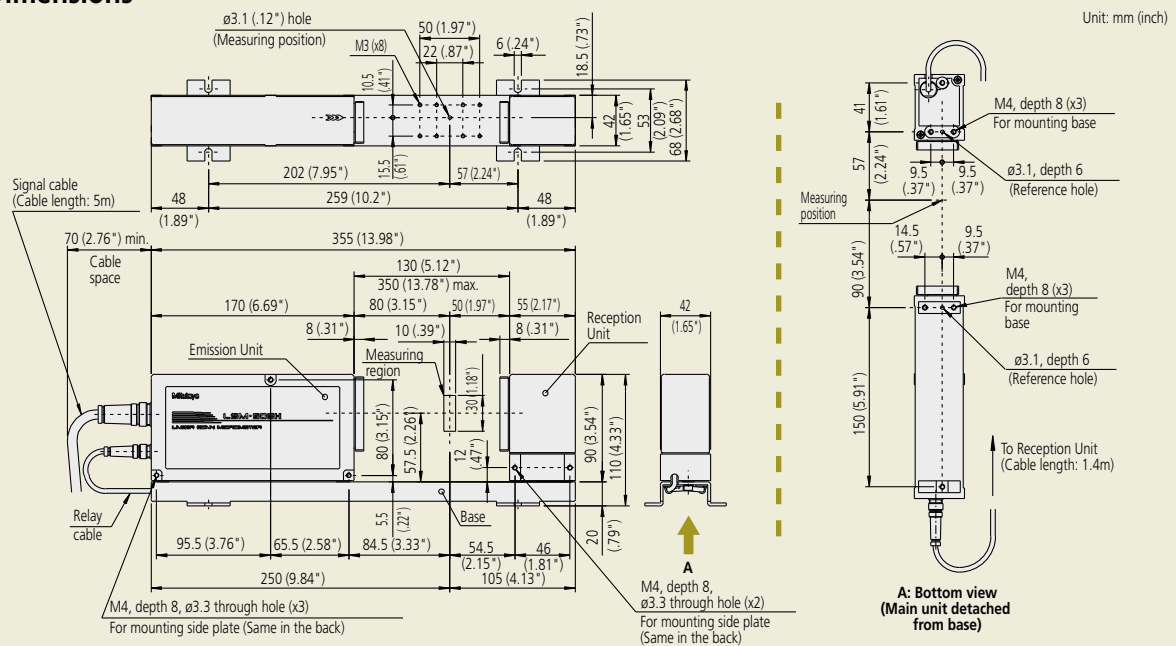

Optional accessories

02AGD130

Calibration gage set (ø1.0mm, ø30mm)



02AGD400

Adjustable workstage

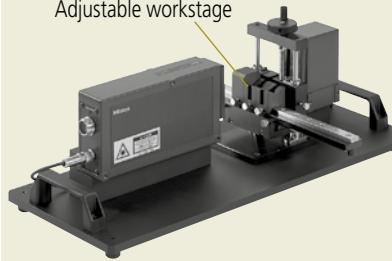

02AGD270

Workstage

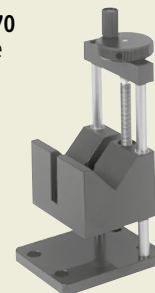

02AGD240

Air-screen covers

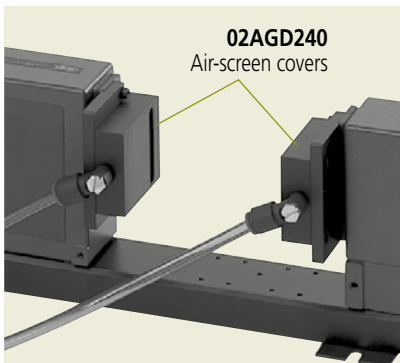

02AGD440

Center support*

02AGD450

Adjustable V-block*

957608

Air cleaner for air-screen covers

02AGC150A

Extension relay cable 1m

02AGC150B

Extension relay cable 3m

02AGC150C

Extension relay cable 5m

02AGN780A

Extension signal cable 5m

02AGN780B

Extension signal cable 10m

02AGN780C

Extension signal cable 15m

02AGN780D

Extension signal cable 20m

*Use with an adjustable workstage.

LSM-506S

Wide Range Measuring Unit

- > General-purpose type with a measurement range of 1mm to 60mm.
- > Provides high accuracy with a linearity of $\pm 3\mu\text{m}$ over the entire measurement range and $\pm(1.5+0.5\Delta D)\mu\text{m}$ in the narrow range.
- > Excellent repeatability of $\pm 0.36\mu\text{m}$

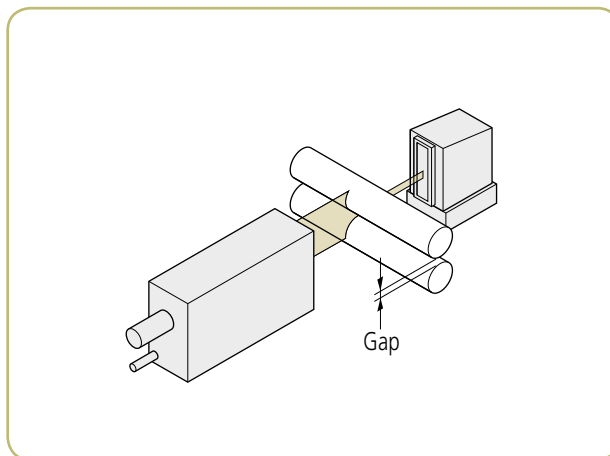
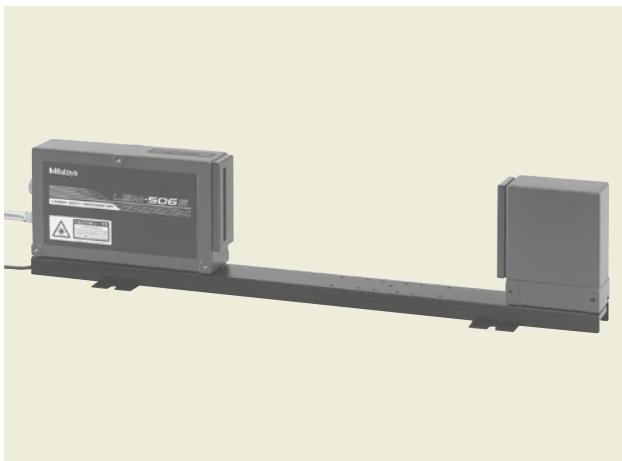

Specifications

Model	LSM-506S	
Order No.	544-537	544-538
Acceptable standard of laser	JIS	IEC, FDA
Measuring range	1 - 60mm (.04" - 2.36")	
Resolution (selectable)	0.00005 - 0.1mm (.000002" - .005")	
Repeatability*1	$\pm 0.36\mu\text{m}$ ($\pm 14\mu\text{inch}$)	
Linearity at 20°C*2	Entire range	$\pm 3\mu\text{m}$ ($\pm 120\mu\text{inch}$)
	Narrow range	$\pm(1.5+0.5\Delta D)\mu\text{m}$
Positional error*3	$\pm 4\mu\text{m}$ ($\pm 160\mu\text{inch}$)	
Measuring region*4	20 x 60mm (.8" x 2.36")	
Scanning rate	3200 scans/s	
Laser wavelength	650nm, Visible*5	
Laser scanning speed	452m/s (17800"/s)	
Operating temperature	0°C - 40°C	
Operating humidity	35 - 85% RH (with no condensation)	
Water/Dust protection grade	Conforming to IP64*6	
Mass	Emission unit: 1.4kg (3.08lbs.), Reception unit: 0.8kg (1.76lbs.), Base: 0.8kg (1.76lbs.), Signal cable: 0.5kg (1.1lbs.)	

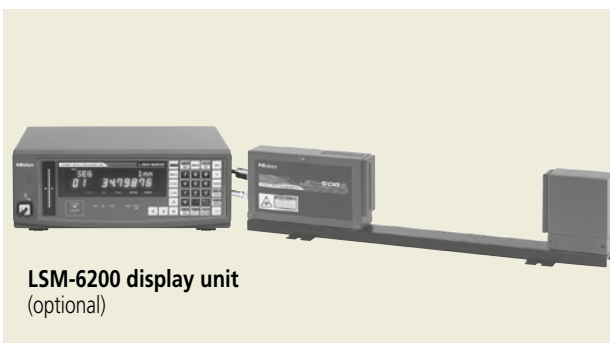
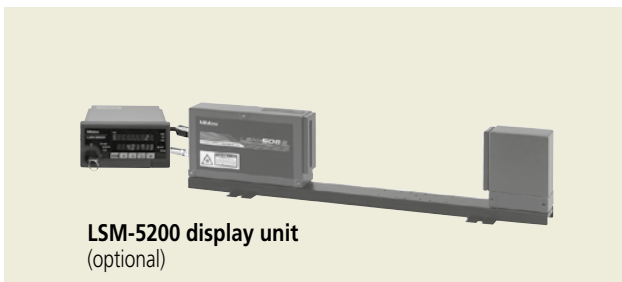
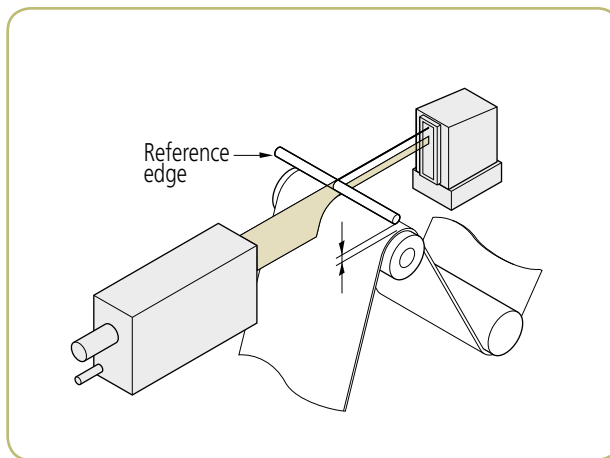

Dimensions

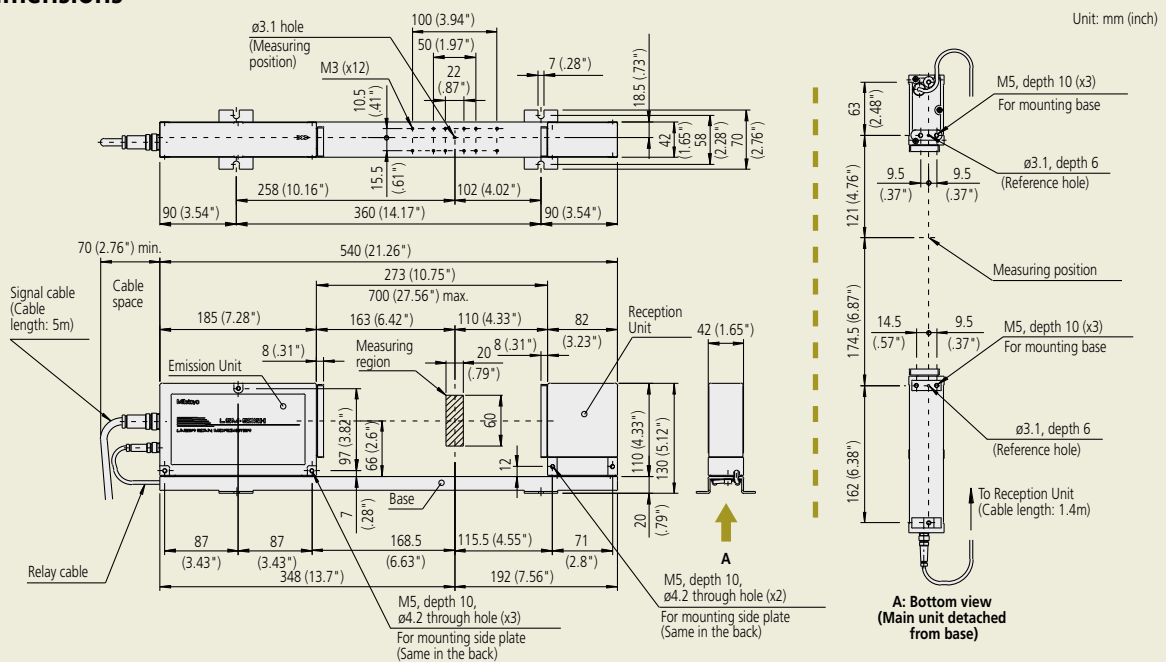

Optional accessories

02AGD140

Calibration gage set ($\phi 1.0\text{mm}$, $\phi 60\text{mm}$)



02AGD520

Adjustable workstage

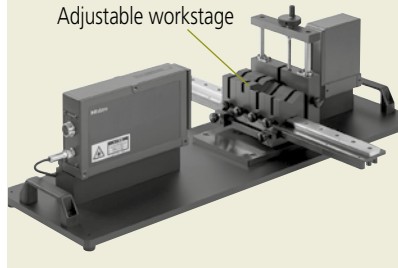

02AGD250

Air-screen covers

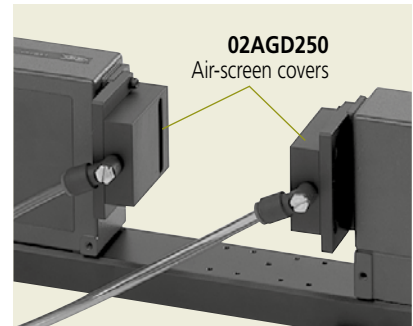

- 02AGD580 Center support*
- 02AGD590 Adjustable V-block*
- 02AGD250 Air-screen cover
- 957608 Air cleaner for air-screen covers
- 02AGC150A Extension relay cable 1m
- 02AGC150B Extension relay cable 3m
- 02AGC150C Extension relay cable 5m
- 02AGN780A Extension signal cable 5m
- 02AGN780B Extension signal cable 10m
- 02AGN780C Extension signal cable 15m
- 02AGN780D Extension signal cable 20m

*Use with an adjustable workstage.

LSM-512S

Ultra-Wide Range Measuring Unit

- › General-purpose type with a wide measurement range of 1mm to 120mm.
- › Provides high accuracy with a linearity of $\pm 6\mu\text{m}$ over the entire measurement range and $\pm(4.0+0.5\Delta D)\mu\text{m}$ in the narrow range.
- › Excellent repeatability of $\pm 0.8\mu\text{m}$

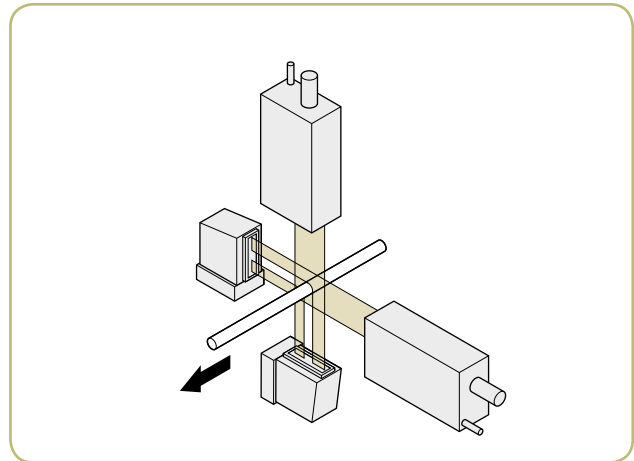
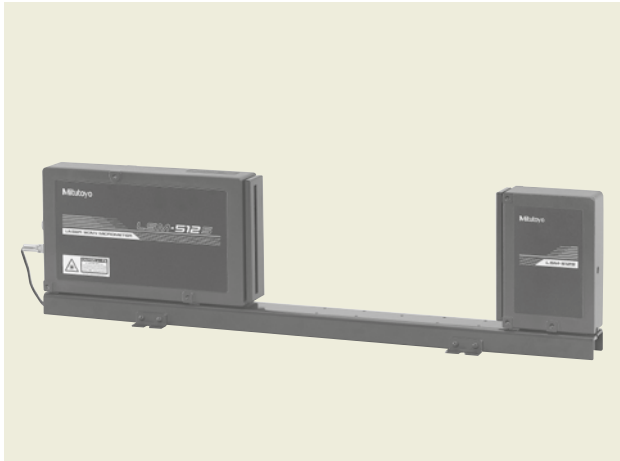

Specifications

Model	LSM-512S
Order No.	544-540
Acceptable standard of laser	IEC, FDA
Measuring range	1 - 120mm (.04" - 4.72")
Resolution (selectable)	0.0001 - 0.1mm (.000005" - .005")
Repeatability*1	$\pm 0.8\mu\text{m}$ ($\pm 32\mu\text{inch}$)
Linearity	Entire range $\pm 6\mu\text{m}$ ($\pm 240\mu\text{inch}$)
at 20°C*2	Narrow range $\pm(4.0+0.5\Delta D)\mu\text{m}$
Positional error*3	$\pm 8\mu\text{m}$ ($\pm 320\mu\text{inch}$)
Measuring region*4	30 x 120mm at $\phi 1 - 120\text{mm}$ (1.2" x 4.72" at $\phi .04" - 4.72"$)
Scanning rate	3200 scans/s
Laser wavelength	650nm, Visible*5
Laser scanning speed	904m/s (35590 °/s)
Operating temperature	0°C - 40°C
Operating humidity	35 - 85% RH (with no condensation)
Water/Dust protection grade	Conforming to IP64*6
Mass	Emission unit: 3.0kg (6.6lbs.), Reception unit: 1.2kg (2.64lbs.), Base: 1.8kg (3.96lbs.), Signal cable: 0.5kg (1.1lbs.)

*1: Determined by the value for $\pm 2\sigma$ at the measurement of $\phi 120\text{mm}$ workpiece with 0.32sec. interval (1024-time average).

*2: At the center of the measuring region.

*3: An error due to workpiece shift either in the optical axis direction or in the scanning direction.

*4: The area given by "measuring range on the optical axis" x "measuring range in the scanning direction".

*5: FDA Class I/IEC Class 2 semiconductor laser for scanning (Maximum power: 1.3mW)

*6: The protection level provided for the interior. If the workpiece or glass of the measuring unit window is soiled by water or dust, the unit may malfunction.

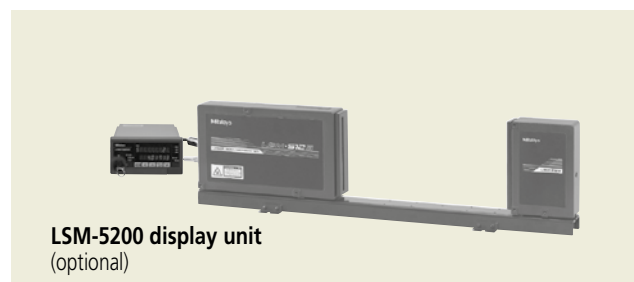
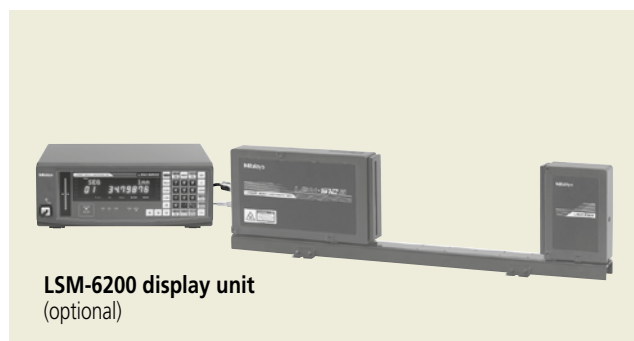
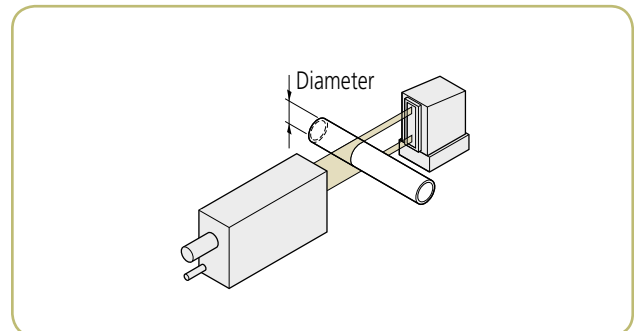

Dimensions

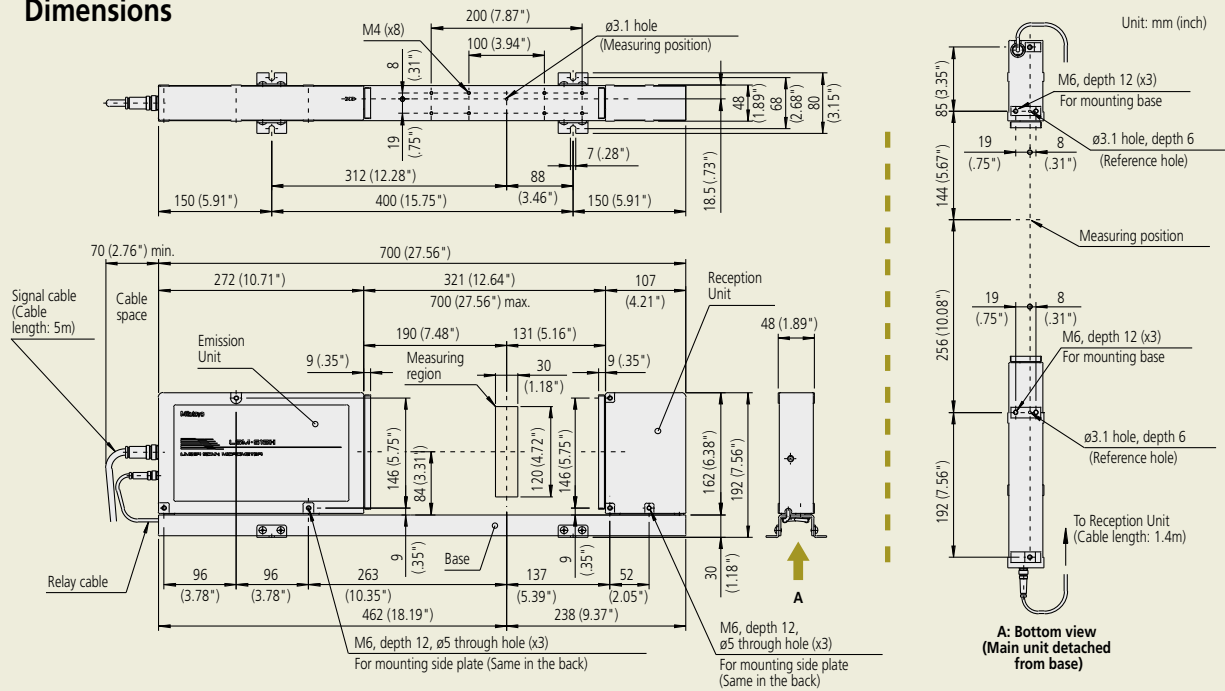

Optional accessories

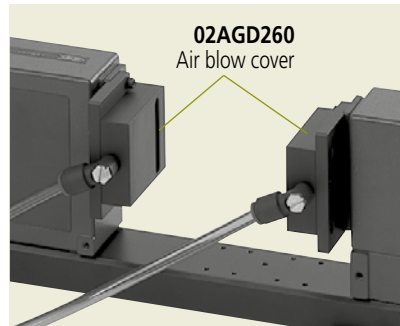

- 957608** Air cleaner for air-screen covers
- 02AGC150A** Extension relay cable 1m
- 02AGC150B** Extension relay cable 3m
- 02AGC150C** Extension relay cable 5m
- 02AGN780A** Extension signal cable 5m
- 02AGN780B** Extension signal cable 10m
- 02AGN780C** Extension signal cable 15m
- 02AGN780D** Extension signal cable 20m

LSM-516S

Ultra-Wide Range Measuring Unit

- > General-purpose type with a wide measurement range of 1mm to 160mm.
- > Provides high accuracy with a linearity of $\pm 7\mu\text{m}$ over the entire measurement range and $\pm(4.0+2.0\Delta D)\mu\text{m}$ in the narrow range.
- > Excellent repeatability of $\pm 1.4\mu\text{m}$

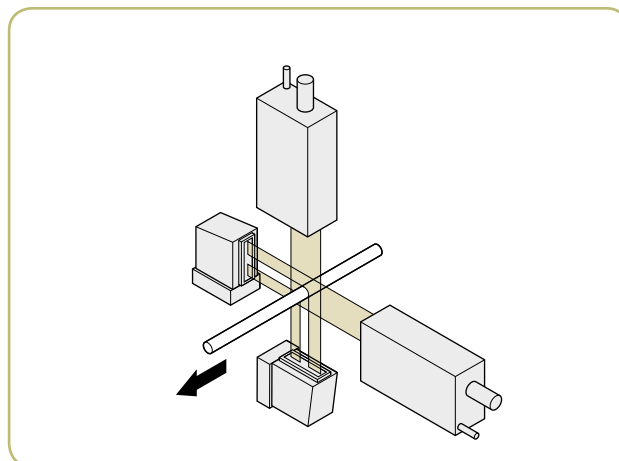

Specifications

Model	LSM-516S
Order No.	544-542
Acceptable standard of laser	IEC, FDA
Measuring range	1 - 160mm (.04" - 6.30")
Resolution (selectable)	0.0001 - 0.1mm (.000005" - .005")
Repeatability*1	$\pm 1.4\mu\text{m}$ ($\pm 55\mu\text{inch}$)
Linearity	Entire range: $\pm 7\mu\text{m}$ ($\pm 276\mu\text{inch}$)
	Narrow range: $\pm(4.0+2.0\Delta D)\mu\text{m}$
Positional error*3	$\pm 8\mu\text{m}$ ($\pm 320\mu\text{inch}$)
Measuring region*4	40 x 160mm at $\phi 1 - 160\text{mm}$ (1.57" x 6.30" at $\phi .04 - 6.30$ ")
Scanning rate	3200 scans/s
Laser wavelength	650nm, Visible*5
Laser scanning speed	603m/s (23740"/s)
Operating temperature	0°C - 40°C
Operating humidity	35 - 85% RH (with no condensation)
Water/Dust protection grade	Conforming to IP64*6
Mass	Emission unit: 3.0kg (6.6lbs.), Reception unit: 1.2kg (2.64lbs.), Base: 1.8kg (3.96lbs.), Signal cable: 0.5kg (1.1lbs.)

- *1: Determined by the value for $\pm 2\sigma$ at the measurement of $\phi 160\text{mm}$ workpiece with 0.32sec. interval (1024-time average).
- *2: At the center of the measuring region.
- *3: An error due to workpiece shift either in the optical axis direction or in the scanning direction.
- *4: The area given by "measuring range on the optical axis" x "measuring range in the scanning direction".
- *5: FDA Class II/IEC Class 2 semiconductor laser for scanning (Maximum power: 1.3mW)
- *6: The protection level provided for the interior. If the workpiece or glass of the measuring unit window is soiled by water or dust, the unit may malfunction.

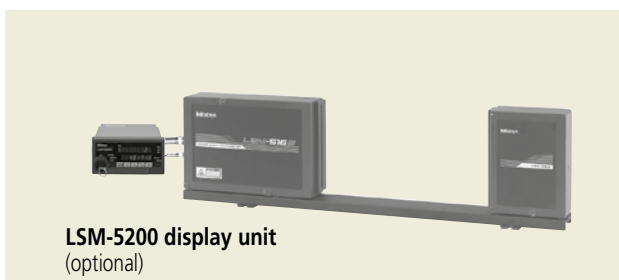
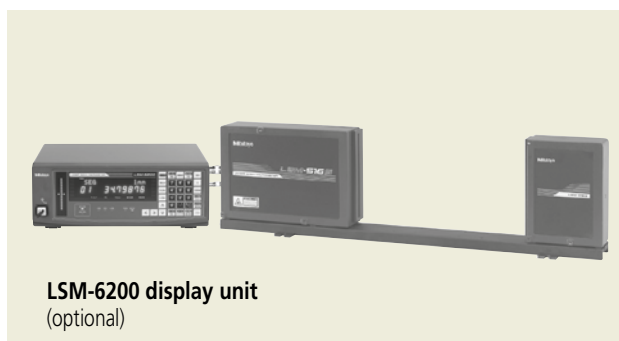
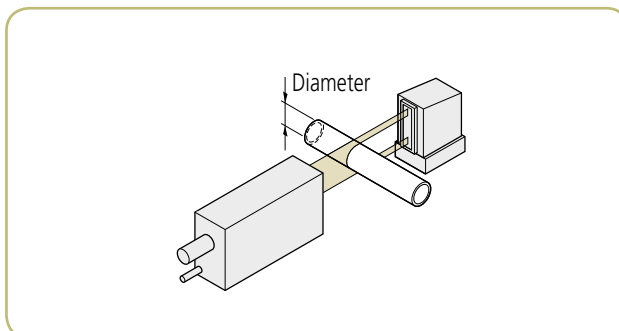

Dimensions

Unit: mm (inch)

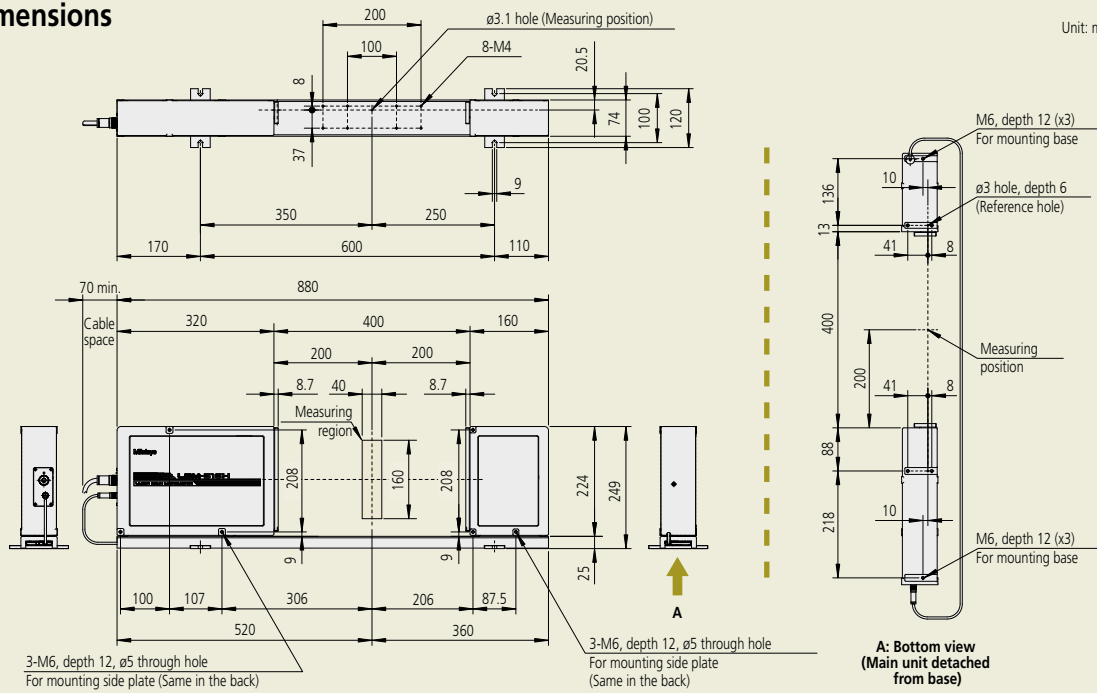

Optional accessories

02AGD300
Calibration gage set
(ø20mm, ø160mm)



- 02AGC150A** Extension relay cable 1m
- 02AGC150B** Extension relay cable 3m
- 02AGC150C** Extension relay cable 5m
- 02AGN780A** Extension signal cable 5m
- 02AGN780B** Extension signal cable 10m
- 02AGN780C** Extension signal cable 15m
- 02AGN780D** Extension signal cable 20m

LSM-9506

Bench-top Type with Display Unit

- › With a design that integrates the display section and measuring section into one unit, this instrument is best suited for making bench-top measurements in an inspection room.
- › A statistical calculation function is provided.
- › Standard RS-232C and SPC output interfaces are provided as standard.



Dimensions

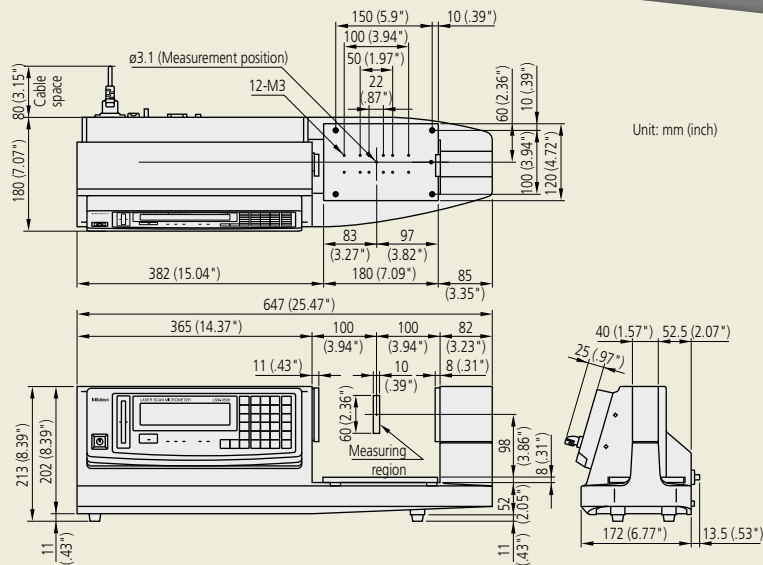

Specifications

Model	LSM-9506		
Order No.	220/230V AC	544-115D	544-116D
(Order no. suffix denotes the AC power cord type equipped.)	240V AC	544-115E	544-116E
Type	mm	inch/mm	
Measuring range	0.5 - 60mm	.02" - 2.36"/0.5 - 60mm	
Resolution (selectable)	0.00005 - 0.1mm	.000002" - .005"/0.00005 - 0.1mm	
Repeatability*1	±0.6µm (±24µinch)		
Linearity at 20°C*2	±2.5µm (±100µinch)		
Positional error*3	In the optical axis direction: ±2.5µm (±100µinch) In the scanning direction: ±(2.0+L/10)µm (±(.00008+L/10000)")		
Measuring region*4	10 x 60mm (.4" x 2.36")		
Scanning rate	1600 scans/s		
Laser wavelength	650nm, Visible*5		
Laser scanning speed	226m/s (8900"/s)		
Power supply	100 - 240V AC ±10%, 50/60Hz, 40VA		
Data output	Via RS-232C interface, SPC (Digimatic) output port		
Functions	(See page 30.)		
Operating temperature	0°C - 45°C		
Operating humidity	35 - 85% RH (with no condensation)		
Mass	13kg (28.6lbs.)		

Optional accessories

02AGD140

Calibration gage set (ø1.0mm, ø60mm)



02AGD680 Adjustable Workstage

02AGD580 Center support*

02AGD590 Adjustable V-block*

936937 SPC output cable (1m)

937179T Footswitch

*Use with an adjustable workstage.

*1: Determined by the value for $\pm 2\sigma$ at the measurement interval of 0.32 sec.

*2: At the center of the measuring region.

*3: An error due to workpiece shift either in the optical axis direction or in the scanning direction. L= Distance between the center of workpiece and the center of optical axis (in mm or inches).

*4: The area given by "measuring range on the optical axis" x "measuring range in the scanning direction".

*5: FDA Class II (544-115A, 544-116A)/IEC Class 2 (All models except 544-115A and 544-116A) semiconductor laser for scanning (Maximum power: 1.0mW)

Optional accessories

Calibration Gage Sets

- The calibration gage sets are made up of precision disks, cylinders or wires used for calibrating Laser Scan Micrometers. Each gauge that may be measured in alternate positions is marked at the position where the calibration measurement was made.



Order No.	Application	Components
02AGD110	LSM-500S	ø0.1mm gage (958200) ø2mm gage (958202) Gage stand (02AGD111) Set case (958203)
02AGD120	LSM-501S	ø0.1mm gage (958200) ø10mm gage (229317) Gage stand (02AGD121) Set case (958203)
02AGD180	LSM-902	ø1mm gage (02AGD920) ø25mm gage (02AGD963)
02AGD130	LSM-503S	ø1mm gage (02AGD920) ø30mm gage (02AGD961) Gage stand (02AGD131) Set case (02AGD980)
02AGD140	LSM-506S	ø1mm gage (02AGD920) ø60mm gage (02AGD962) Gage stand (02AGD141) Set case (02AGD980)
02AGD150	LSM-512S	ø20mm gage (229730) ø120mm gage (234072) Gage stand (02AGD151) Set case (02AGD990)
02AGM300	LSM-516S	ø20mm gage (229730) ø160mm gage (02AGM303) Gage stand (02AGM320) Set case (02AGM310)
02AGD170	LSM-9506	ø1mm gage (02AGD920) ø60mm gage (02AGD962) Gage stand (02AGD171) Set case (02AGD970)

*Not available for LSM-902

Extension Signal Cables

- Used to extend the supplied signal cable if the measuring unit and display unit need to be placed further apart from one another.

Extension Relay Cables*

- Used to extend the supplied relay cable if the emission unit and reception unit need to be placed further apart from one another.

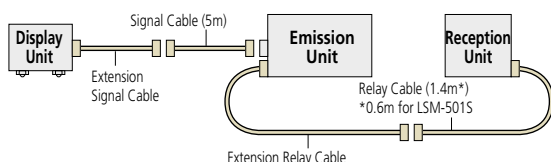

Extension signal cables

Order No.	Cable length
02AGN780A	5m
02AGN780B	10m
02AGN780C	15m
02AGN780D	20m

Extension relay cables

Order No.	Cable length
02AGC150A	1m
02AGC150B	3m
02AGC150C	5m

Note 1: The maximum length of the LSM-500S/501S signal cable is 20m, and that of the relay cable is 2m. The maximum length of the signal and relay cables of models other than those mentioned above should be 30m or less and 5m or less, respectively.
 Note 2: The total length of signal and relay cables should not be more than 32m.

Workstage

- Aids shaft measurement by providing a V-block mounting and an up/down adjustment mechanism.

Order No.	Application
02AGD270	LSM-501S LSM-503S LSM-902

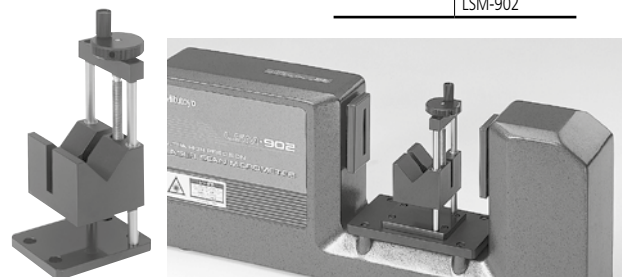

Wire Guiding Pulleys

- This jig is for guiding thin filaments, such as fine magnet wire or optical fiber, so that a stable measurement of the outside diameter can be made.

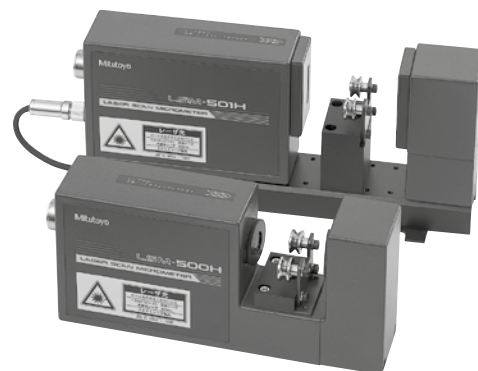

Order No.	Application	Maximum measuring dia.
02AGD200	LSM-500S	1.6mm (.063")
02AGD210	LSM-501S	2mm (.079")

Note: Use the calibration gage set (02AGD110) for both types of wire guiding pulley.

Air-Screen System

- If using your LSMs in a smoky or dusty environment, an air-screen system consisting of two covers per unit and a central air cleaner/regulator can be used to help prevent the emission/reception windows from being soiled.

Air cleaner/regulator: 957608

Air-screen covers

Order No.	Application	No. of pcs.*
02AGD220	LSM-500S	6 pcs.*
02AGD230	LSM-501S	6 pcs.*
02AGD240	LSM-503S	3 pcs.*
02AGD250	LSM-506S	1 pc.*
02AGD260	LSM-512S	1 pc.*



* No. of pcs. concurrently usable with one air cleaner/regulator.

Optional accessories for Laser Scan Micrometer Adjustable Workstages

- > Aids in measuring workpiece diameter by means of up/down and right/left slide adjustments.
- > Optimum for quality control of precision shafts, rollers, pin gages, etc.

For LSM-902/6900

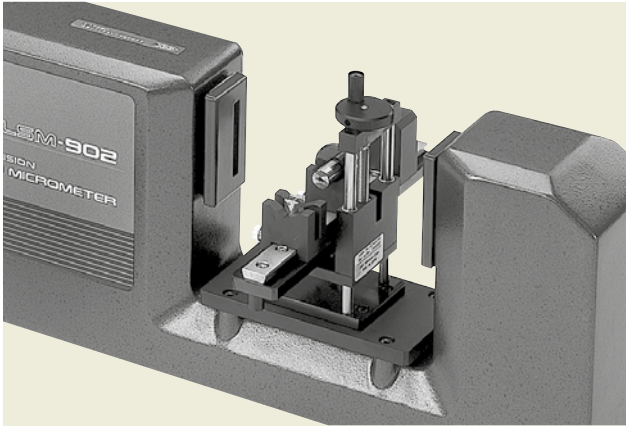

Specifications

Order No.	02AGD280
Application	LSM-902
Horizontal adjustment	130mm (5.12")
Vertical adjustment	47mm (1.850")
Maximum table loading	0.5kg (1.1lbs.)
Mass	0.8kg (1.8lbs.)
Standard accessories	<ul style="list-style-type: none"> •V-block (02AGD420) x 2pcs. •Workpiece stop (02AGD430)

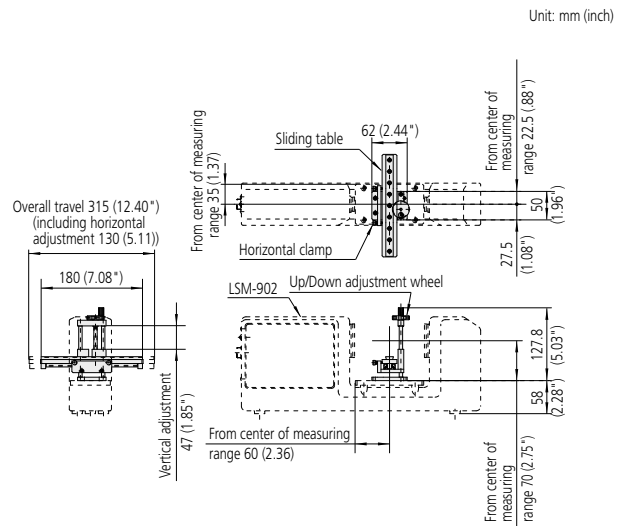

For LSM-501S

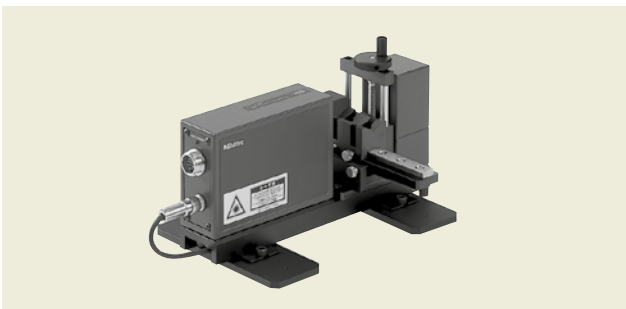

Specifications

Order No.	02AGD400
Application	LSM-501S
Horizontal adjustment	130mm (5.12")
Vertical adjustment	32mm (1.26")
Maximum table loading	0.5kg (1.1lbs.)
Mass	1.0kg (2.2lbs.)
Standard accessories	<ul style="list-style-type: none"> •V-block (02AGD420) x 2pcs. •Workpiece stop (02AGD430)

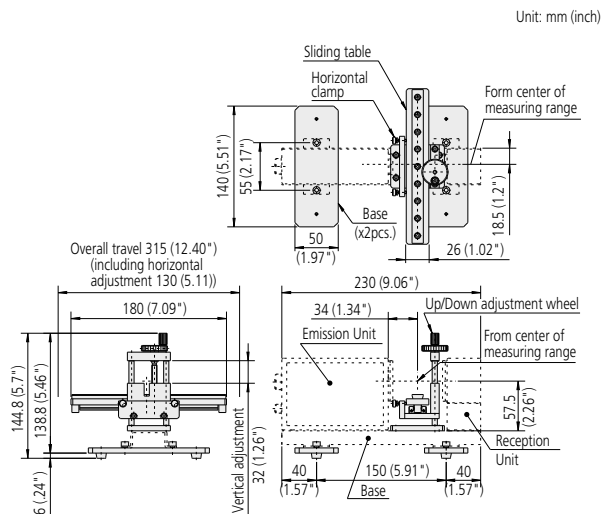

For LSM-503S

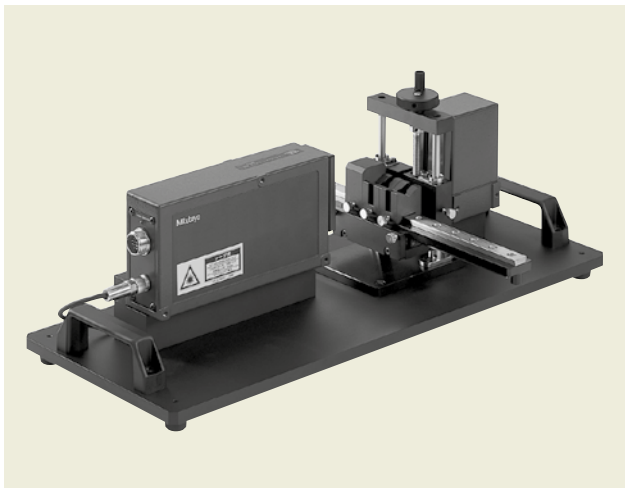

Specifications

Order No.	02AGD490
Application	LSM-503S
Horizontal adjustment	200mm (7.87")
Vertical adjustment	35mm (1.38")
Maximum table loading	2.0kg (4.4lbs.)
Mass	4.9kg (10.78lbs.)
Standard accessories	<ul style="list-style-type: none"> •V-block (02AGD420) x 2pcs. •Workpiece stop (02AGD430)

Unit: mm (inch)

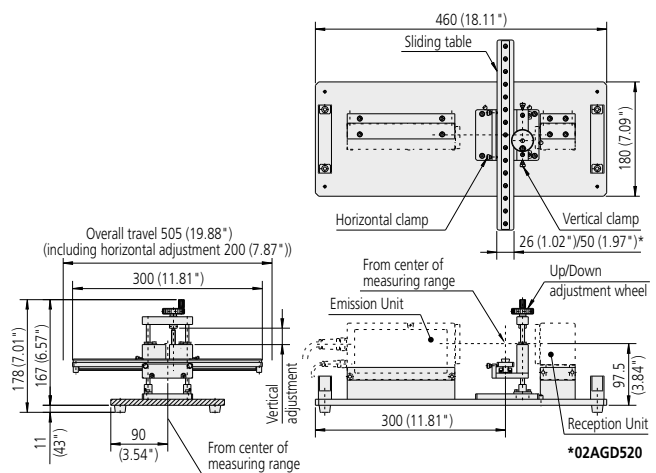

Standard Accessories

V-blocks

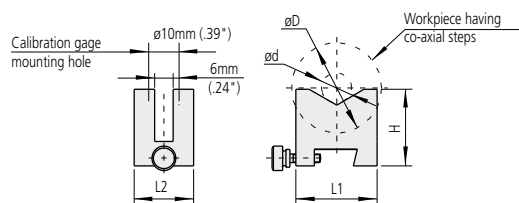

Unit: mm (inch)

Order No.	02AGD420
øD max.	30 (1.18")*
ød max.	30 (1.18")*
D - d max.	25 (.98")**
H	25.5 (1")
L1	27 (1.06")
L2	20 (.79")
Mass	0.03kg
Calibration gages to be used	•ø0.1mm •ø1mm •ø10mm •ø30mm

*10 (.39") for LSM-501S **25 (.98") for LSM-902

Workpiece stop

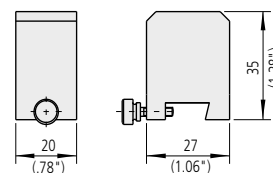

Order No.	02AGD430
Mass	0.05kg

Optional accessories for Laser Scan Micrometer Adjustable Workstages

- > Aids in measuring workpiece diameter by means of up/down and right/left slide adjustments.
- > Optimum for quality control of precision shafts, rollers, pin gages, etc.

For LSM-506S

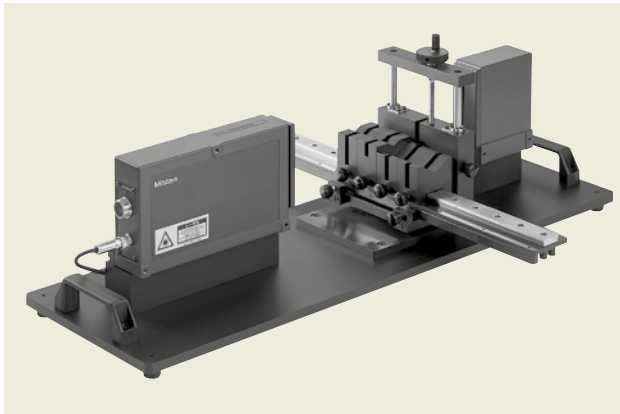

Specifications

Order No.	02AGD520
Application	LSM-506S
Horizontal adjustment	300mm (11.81")
Vertical adjustment	45mm (1.77")
Maximum table loading	5.0kg (11lbs.)
Mass	9.7kg (21.34lbs.)
Standard accessories	<ul style="list-style-type: none"> •V-block (02AGD550) x 2pcs. •V-block (02AGD560) •V-block (02AGD570)

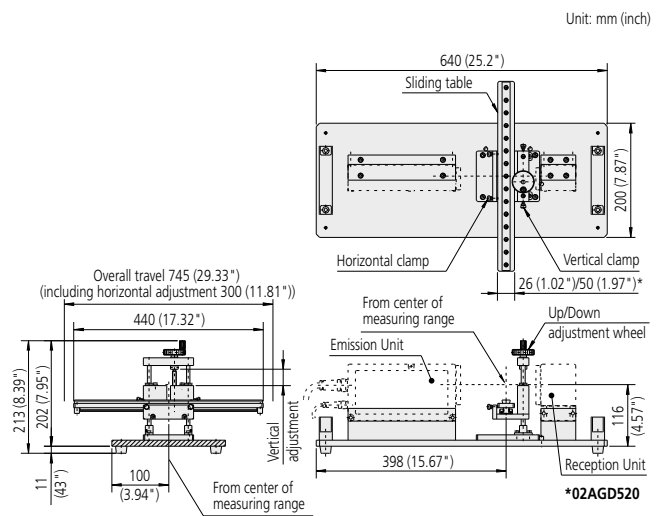

For LSM-9506

Specifications

Order No.	02AGD370	02AGD680
Application	LSM-9506	
Horizontal adjustment	200mm (7.87")	300mm (11.81")
Vertical adjustment	45mm (1.77")	
Maximum table loading	2.0kg (4.4lbs.)	5.0kg (11lbs.)
Mass	3.8kg (8.4lbs.)	4.8kg (10.56lbs.)
Standard accessories	<ul style="list-style-type: none"> •V-block (02AGD550) x 2pcs. •V-block (02AGD560) •V-block (02AGD570) 	

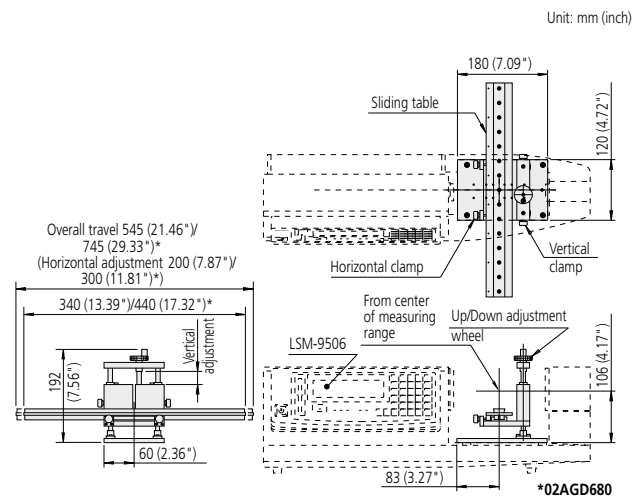

Standard Accessories

V-blocks

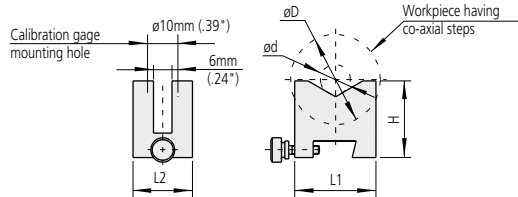

Unit: mm (inch)

Order No.	02AGD550	02AGD560	02AGD570
øD max.	60 (2.36")	60 (2.36")	60 (2.36")
ød max.	60 (2.36")	30 (1.18")	30 (1.18")
D - d max.	30 (1.18")	50 (1.97")	50 (1.97")
H	39 (1.54")	45 (1.77")	45 (1.77")
L1	50 (1.97")	50 (1.97")	50 (1.97")
L2	30 (1.18")	30 (1.18")	30 (1.18")
Mass	0.12kg	0.15kg	0.15kg
Calibration gages to be used	<ul style="list-style-type: none"> • ø10mm • ø30mm 	<ul style="list-style-type: none"> • ø10mm • ø30mm • ø60mm 	<ul style="list-style-type: none"> • ø1mm • ø10mm • ø30mm

Optional accessories

Adjustable V-blocks

- Optional accessories for adjustable workstages.

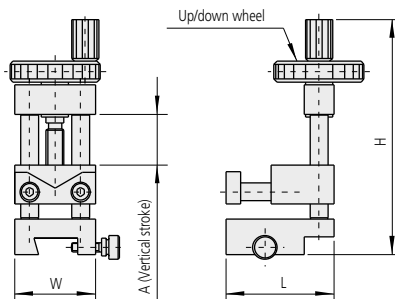

Unit: mm (inch)

Order No.	02AGD450	02AGD590
H	78.8 (3.1")	105.8 (4.17")
L	36 (1.42")	40 (1.57")
W	27 (1.06")	50 (1.97")

Specifications

Order No.	02AGD450	02AGD590
Application	Adjustable workstage for LSM-501S (02AGD400), Adjustable workstage for LSM-902 (02AGD280), Adjustable workstage for LSM-503S (02AGD490)	Adjustable workstage for LSM-506S (02AGD520), Adjustable workstage for LSM-9506 (02AGD680)
Vertical adjustment (A)	20mm (.79")	35mm (1.38")
Maximum workpiece diameter	30mm (1.18")	60mm (2.36")
Mass	0.1kg	0.2kg

Center Supports

- Optional accessories for adjustable workstages.

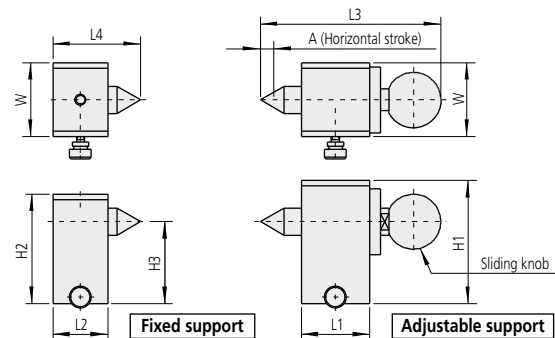

Unit: mm (inch)

Order No.	02AGD440	02AGD580
H1	45 (1.77")	65 (2.56")
H2	40 (1.57")	60 (2.36")
H3	30 (1.18")	45 (1.77")
L1	25 (.98")	50 (1.97")

Unit: mm (inch)

Order No.	02AGD440	02AGD580
L2	20 (.79")	40 (1.57")
L3	66 (2.60")	106.5 (4.19")
L4	32 (1.26")	55 (2.17")
W	27 (1.06")	50 (1.97")

Specifications

Order No.	02AGD440	02AGD580
Application	Adjustable workstage for LSM-501S (02AGD400), Adjustable workstage for LSM-902 (02AGD280), Adjustable workstage for LSM-503S (02AGD490)	Adjustable workstage for LSM-506S (02AGD520), Adjustable workstage for LSM-9506 (02AGD680)
Point angle	60°	60°
Maximum workpiece length	110mm (4.33") on 02AGD400/02AGD280 230mm (9.06") on 02AGD490	315mm (12.4") on 02AGD520 on 02AGD680
Horizontal adjustment (A)	5mm (.2") or more	10mm (.39") or more
Center point clamping force	1.1kgf	3.2kgf
Mass	0.18kg (.4lbs.)	0.85kg (1.87lbs.)

LSM-5200

Compact (Panel-mount) Type Display Unit

- › Panel-mount type (with dimensions conforming to DIN standards) allows easy system integration.
- › Capable of calculating mean, maximum, minimum, and range (maximum - minimum).
- › Segment measurement (7 segments max.) or edge measurement (1 to 255 edges) can be selected.
- › USB2.0, RS-232C and I/O-Analog interfaces are provided as standard.
- › Arithmetical average or moving average can be selected.
- › GO/±NG judgment function.

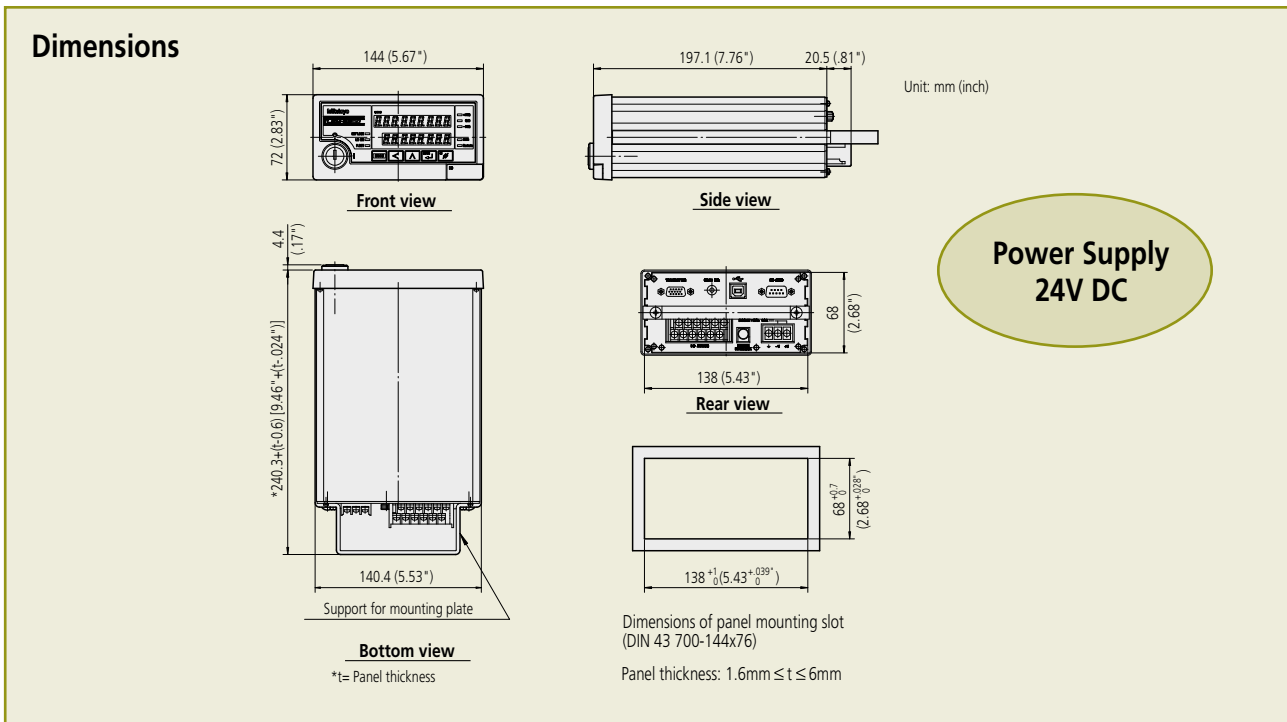

Specifications

Model	LSM-5200
Order No.	544-047
Display	9-digit LED (for measurement) & 8-digit LED (sub-display)
Segment designation	Seg.1 to Seg.7 (Seg.1 - Seg.3 for transparent objects)
Edge designation	1 to 255 edges can be detected*1
Averaging times*2	Arithmetical average: per 1 to 2048, moving average: per 32 to 2048
GO/±NG judgment	Nominal value ±tolerance setting, upper & lower limits setting
Measurement mode	Waiting, single measurement, continuous measurement
Statistical calculation	Available when connecting an external PC via the RS-232C or USB interfaces
Power supply	+24V DC ±10%, 1A
Data output	USB2.0, RS-232C and I/O-Analog interfaces
Functions	(See page 30.)
Operating temperature	0°C - 45°C
Operating humidity	35 - 85% RH (with no condensation)
Mass	1.4kg (3.08lbs.)

*1: With the **LSM-500S** the measuring range will be set to between 0.1 and 2mm if edge measurement is selected for 1 to 255 edges or if the automatic workpiece detecting function is on.

*2: With the **LSM-500S** the number of scans will be limited to between 16 and 2048 for both arithmetical and moving averages if the ultra-fine wire measurement function is on.

LSM-6200

Multi-function Type Display Unit

- › With a dual-display design setup values can be continuously monitored. Also, two measurement value items can be displayed on the sub-display with the simultaneous measurement function.
- › Either segment measurement (7 segments max.) or edge measurement (1 to 255 edges) can be selected.
- › RS-232C and I/O-Analog interfaces are provided as standard.
- › A statistical calculation function and abnormal data eliminating function are provided.



Dimensions

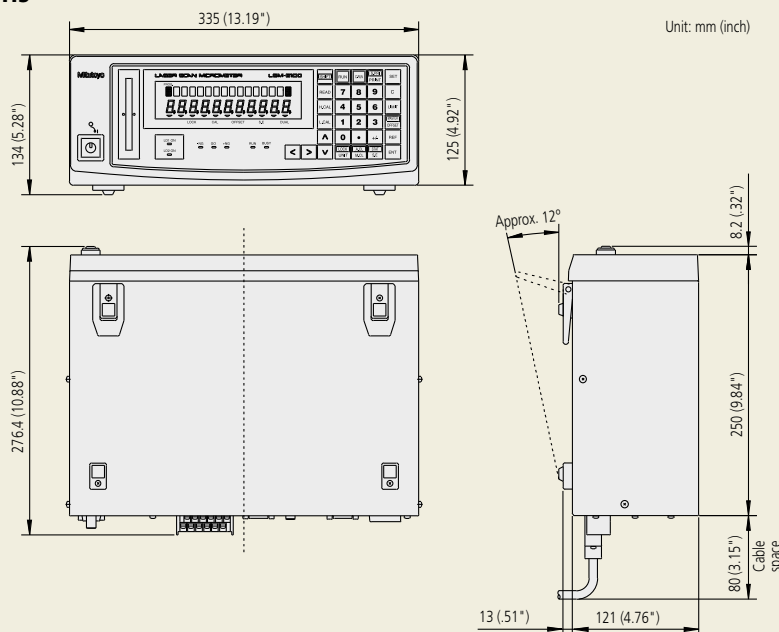

Specifications

Model	LSM-6200		
Order No.	100/110V AC	544-071C	544-072C
(Order no. suffix denotes the AC power cord type equipped.)	120V AC	544-071A	544-072A
	220/230V AC	544-071D	544-072D
	240V AC	544-071E	544-072E
	240V AC ›	544-071F	544-072F
	Type	mm	inch/mm
Display	16-digit fluorescent tube (for measurement) & 11-digit fluorescent tube (sub-display)		
Segment designation	Seg.1 to Seg.7 (Seg.1 - Seg.3 for transparent objects)		
Edge designation	1 to 255 edges can be detected*1		
Averaging times*2	Arithmetical average: per 1 to 2048, moving average: per 32 to 2048		
GO/±NG judgment	Nominal value ±tolerance setting, upper & lower limits setting, multi-limit setting		
Measurement mode	Waiting, single measurement, continuous measurement		
Statistical calculation	Maximum measurement (MAX), minimum measurement (MIN), mean, range (MAX-MIN), standard deviation (σ)		
Power supply	100 - 240V AC ±10%, 50/60Hz, 40VA		
Data output (as standard)	Via RS-232C and I/O-Analog interfaces		
Functions	(See page 30.)		
Operating temperature	0°C - 45°C		
Operating humidity	35 - 85% RH (with no condensation)		
Mass	5kg (11lbs.)		

› For Australia

*1: With the **LSM-500S** the measuring range will be set to between 0.1 to 2mm if the edge measurement is selected for 1 to 255 edges or if the automatic workpiece detecting function is on.

*2: With the **LSM-500S** the number of scans will be limited to between 16 and 2048 for both the arithmetical and moving averages if the ultra-fine wire measurement function is on.

LSM-5200/6200/6900/9506 Functions

Measuring Setup Memory

The measuring setup can be registered as a program and saved (LSM-6200: 100 programs, LSM-6900: 10 programs, LSM-5200: 1 program). These programs can be recalled with a single operation.

Multiple Calibration Data Memory Function

This function allows storage of 10 types of calibration data. In this function mode, up to 10 sets of 10 programs are available in hand.

- 10 programs (a piece of calibration data) X 10 sets
- * LSM-6200 can only support this function.

Drill/Endmill (odd number flute) diameter measurement*

*Only for LSM-6900

The diameter of drills or endmills that have an odd number of flutes can be measured by using the max/min value function.

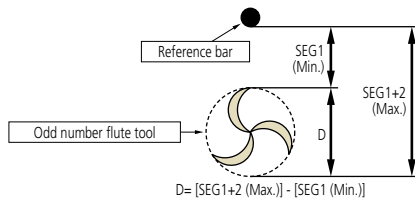

Automatic Workpiece Detection

This function automatically starts measurement when a workpiece advances into the specified measuring area.

Preset/Offset

Sets the currently displayed measurement value to zero or a specified numeric value. This is useful, for example, if a difference in the diameters of a reference gage and a workpiece is to be allowed for in calibration, or if a dimension of a workpiece that exceeds the measurement range of the LSM is to be measured.

Mastering

For continuous processing of high-precision workpieces, fine-adjusting the preset or offset value is called mastering. By specifying a mastering value the total correction will be (zero-set/offset value) + (±mastering value). If a positive mastering value is specified, the displayed value for a workpiece diameter measurement will be greater than the actual value; if a negative value is specified, the displayed value will be smaller than the actual value.

Sample Measurement

On a sample measurement the number of measurements will be defined (in the range of 2 to 999) in advance. From this sample measurement various calculation results (mean, maximum, minimum, and range) can be derived. These measurements can be used for runout measurements on a revolving workpiece and simplified cylindricity measurements.

Arithmetical Average/Moving Average

Arithmetical/moving average modes are provided to obtain the average of measurement values. On this type of LSM either of them can be specified before starting measurement. In the arithmetical average mode, the number of scans over which to take an averaging can be set at one of twelve steps between 1 (0.32ms) and 2048 (0.64sec). In the moving average mode the number of scans can be set at one of seven steps between 32 (0.01sec) and 2048 (0.64sec), and the measurement value will be updated every sixteen scans on and after the second measurement, irrespective of the specified number of scans for averaging. The latter mode is suitable for judging the trend in the diameter or width of an endless workpiece such as wire or tape from a measurement that requires a long period.

Measurement using Segment Specification

The following conventions are used to set up to the maximum of seven segments. However, if the transparent object measuring mode is set, no more than three segments can be set at one time.

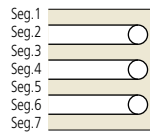

- Measurement of spacing of two parallel pins (pitch measurement)
Pitch = ((Seg.2+Seg.4)/2)+Seg.3

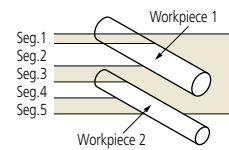

- The Runout of a revolving workpiece can be obtained by observing the variation in Seg.1 which is measured against a stationary reference pin.

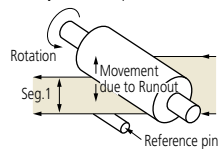

- The outside diameter of a wire or cylindrical workpiece can be measured by using Seg.2.

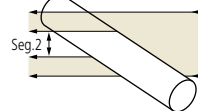

- The outside diameter of a large workpiece can be measured by using Seg.1 and Seg.5 in a dual-unit configuration. (only with LSM-6200).

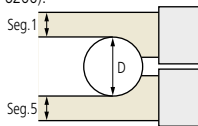

- If dimensions in both X and Y directions (min. distance of X/Y scanning section: 10mm) are measured through dual-unit measurement, use Seg.2 and Seg.6 (only with LSM-6200).

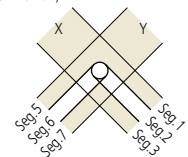

Automatic Measurement using Edges

The edges created by scanning a workpiece can be used to program an LSM. A maximum of 127 workpiece features, and 127 of the spaces between these features, can be used which involves a total of 255 edges. This is most useful for measuring such things as IC chip leads or connector pins that are approximately equally spaced. This method cannot be applied to transparent objects.

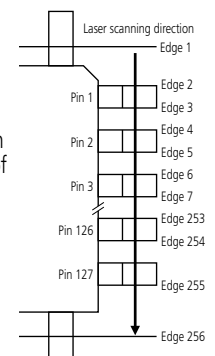

External trigger signal input* *Not available for LSM-5200

By supplying a contact signal to the footswitch connector at the rear panel of the LSM-6200/6900/9506, the measurement can be triggered.

Abnormal Data Elimination

If a piece of data significantly exceeds the tolerance limit because the workpiece or measuring unit is contaminated by a water droplet, oil droplet, or dust, the piece of data will be automatically removed by this function.

Data Output Interval Setting

By setting an interval (between 1 and 999 seconds) to continuous measurement in advance, data output will take place at each specified period of time.

Statistical Calculation

With this function, multiple measurements are taken from the same kind of workpiece, statistical values are calculated from the measurement results and quality evaluation is executed for each lot.

- Example of measuring a stepped cylinder using the statistical calculation function.

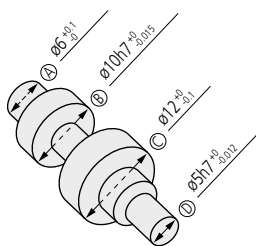

Measuring procedure: Measure the dimensions numbered (A) to (D), perform tolerance judgment, and statistically process the resulting data for every ten samples defined as one lot.

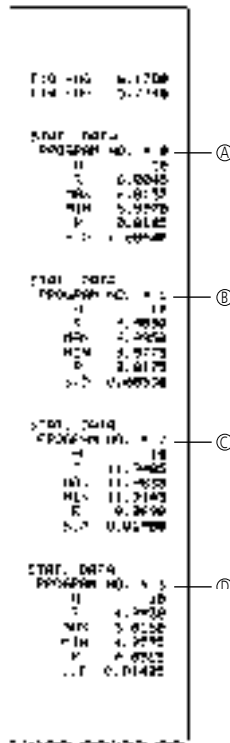

Data Output

Every model has a standard RS-232C interface unit, allowing data to be output to an external PC or printer.

The LSM-5200/6200 has the standard I/O-Analog output interface that allows the LSM to be connected to a sequencer, etc. The SPC (Digimatic Code) output interface is standard with the LSM-9506, allowing for easy construction of a quality control system. With the LSM-6200 there are additional means of data output, including SPC, BCD, and GP-IB output interfaces, which can be incorporated.

Multi-Limit Judgment* *Not available for LSM-5200

In addition to +NG, GO, and -NG judgment criteria limit values from Limit 1 to Limit 6 can also be set. If an optional 2nd I/O-Analog interface unit (02AGC880) is used with the LSM-6200/6900/9506, seven-step judgment signals can be output to external devices to support GO/NG judgment.

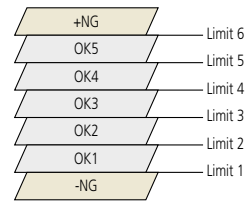

Simultaneous (Dual-program) Measurement* *Not available for LSM-5200

It is possible to measure two items simultaneously with one Laser Scan Micrometer unit, and to output the data. This function can be used to simultaneously measure the outside diameter and runout of a bar that is rotating, or to measure the outside diameters of two cylinders or wires at the same time.

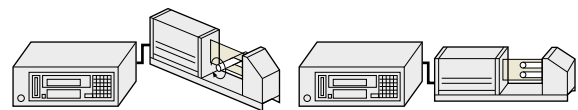

Restrictions Associated with Particular Combinations of Functions

Combinations of Functions	Edge specification		Transparent object measurement	Ultra-fine wire measurement*	Automatic workpiece detection	Abnormal data elimination	Sample measurement	Moving average	Group judgment**
	Manual measurement	Automatic measurement							
Edge specification	Manual measurement	—	—	—	●	●	●	●	●
	Automatic measurement	—	—	—	●	—	—	—	—
Transparent object measurement	—	—	—	●	●	●	●	●	●
Ultra-fine wire measurement*	—	—	●	—	—	●	●	●	●
Automatic workpiece detection	●	●	●	—	—	●	●	—	●
Abnormal data elimination	●	—	●	●	●	—	●	●	●
Sample measurement	●	—	●	●	●	●	—	●	●
Moving average	●	—	●	●	—	●	●	—	—
Group judgment**	●	—	●	●	●	●	●	—	—

●: Permitted combination, —: Combination that is not permitted

*Function that is not provided for LSM-9506

**Function that is not provided for LSM-5200

LSM-5200/6200/6900/9506 Data I/O Specifications

RS-232C Interface

Allows the LSM to communicate with external devices via RS-232C (conforming to the EIA standard) serial signals. Depending on the basic setup this interface can be used as a printer port.

Pin assignment of the connector

Matching plug: D-sub 9pin (female)

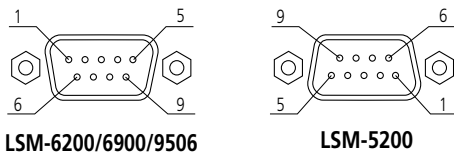

Communication Specifications

Definition of device	DTE definition on the side of LSM
Data transmission method	All-duplex transmission
Synchronizing method	Start-stop system
Data transmission speed	6200 4800, 9600, 19200, 38400bps
	5200, 6900 1200, 2400, 4800, 9600, 19200bps
Data arrangement	Transmission code ASCII
	Data length 7 or 8 bits
	Start bit 1 bit
	Parity check Non, odd or even
	Delimiter CR+LF, CR, LF

Commands

Various external commands, including those for setting measuring conditions, setting the measurement mode, starting measurement, and requesting statistical calculation, are supported. This allows the user to control the LSM from an external unit (e.g. PC) for customized measurements.

Connections

(1) Connecting the RS-232C interface to a device specified as a terminal (DTE)

Example 1: Flow control method (handshake method controlled by CTS, DSR, DTR, and RTS signals)

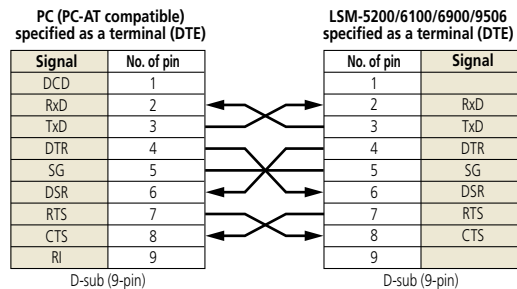

Example 2: Flow control method (handshake method controlled by CTS, DSR, DTR, and RTS signals)

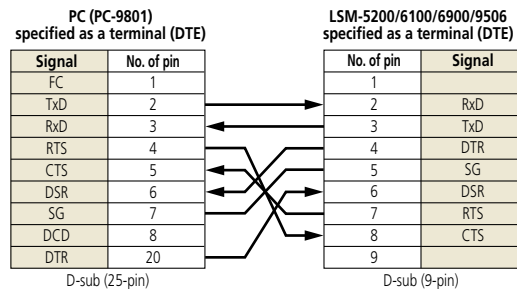

Example 3: 3-Wire method (teletype protocol using Tx/D, Rx/D and SG)

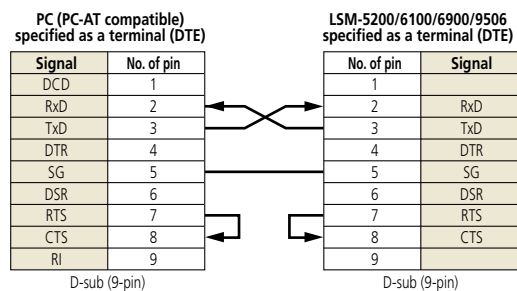

(2) Connecting the RS-232C interface to a device specified as a modem (DCE)

Example 1: Flow control method (handshake method controlled by CTS, DSR, DTR, and RTS signals)

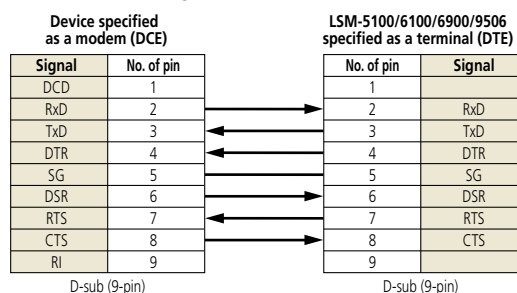

*Not available for LSM-9506

I/O-Analog Interface*

Used to communicate with a PC, programmable controller, or relay circuitry by means of sequential signals. It is also capable of producing an analog voltage output that may be used for feedback control and/or continuous recording of workpiece dimension deviation.

External view of the connector

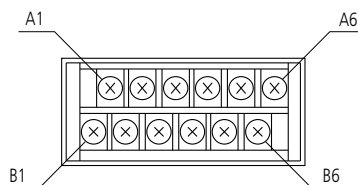

Pin assignment (of LSM-6200/6900)

Terminal	Signal	Function	I/O
A1	FG	Frame ground (Used for connecting the shield conductor of I/O signal cables)	—
A2	STS	Output of measurement condition (Goes high in the event of "Err-0")	OUT
A3	\overline{GO}	GO/NG judgment result output (\overline{GO}) (Can be changed to strobe signal (\overline{STB}) or measurement in-progress signal (ACK) output by the basic setup)	OUT
A4	$\overline{+NG}$	GO/NG judgment result output ($\overline{+NG}$)	OUT
A5	$\overline{-NG}$	GO/NG judgment result output ($\overline{-NG}$)	OUT
A6	GND	Digital ground (Common ground terminal of both output (A2 thru A5) and input (B4 thru B6))	—
B1	FG	Frame ground (Used for connecting the shield conductor of I/O signal cables)	—
B2	ALG	Analog voltage output	OUT
B3	0V	0V reference for analog voltage output	OUT
B4	OFFS	Offset input (Can be changed to (HOLD) by the basic setup)	IN
B5	RUN	Input of trigger command for single-run measurement (Can be changed to a trigger for continuous-run measurement (with term specification))	IN
B6	RES	Input of CLEAR command	IN

Note: The pin assignment for the LSM-5100 may differ.

Input/output equivalent circuit

(1) Input circuit

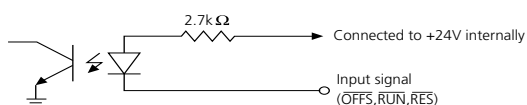

- Low-level signal to be between 0 and 1V. Generally drive this circuit with an open collector-type transistor.
- Maximum current drawn from the input signal terminal is 12mA.

(2) Output circuit

1. Control signal output

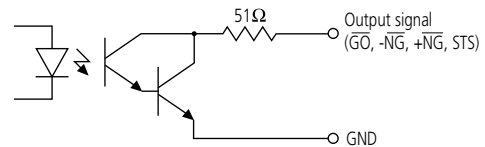

- Maximum rating of the output transistor is 30V, 50mA.

2. Analog signal output

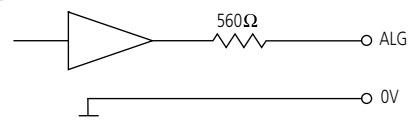

- The output voltage range is $\pm 5V$.
- The accuracy of the analog voltage output is 0.2% of full-scale range.
- This analog output should be connected to a device that has an input impedance of $1M\Omega$ or greater. If the input impedance is lower than this value, the output accuracy will be reduced due to the internal resistance of 560Ω .

Remote Interlock Connector

The Remote Interlock Connector is provided as a means of turning the laser beam on and off from a remote location. Since the supplied short-circuit pin is usually inserted in this terminal, the circuit is short-circuited. Insert an optional switched plug to allow external control of the LSM laser.

Laser emission ON: Short-circuit pin inserted
Laser emission OFF: Short-circuit pin removed



No.214938

Scanning Signal Connector

The Scanning Signal Connector is provided for observing the output signal waveform from the reception chip in the measuring unit. Typically, this connector is used to align the emission unit and reception unit after they have been removed from the original base and then mounted on a different base.



No.02AGC401

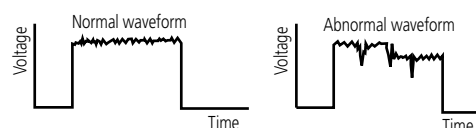

Optional accessories

LSM Control/Data Processing Software LSMPAK Available in the near future



■ Outline

This software can import measurement data from multiple LSM-5200 Display Units to a personal computer, allowing a variety of measuring systems to be constructed.

■ Features

- Capable of processing a maximum of 10 channels of measured-point data (USB-HUB connection).
- Capable of composite calculation between Measuring Units (multiple channels), statistical calculation, and calculation results output as a file.

■ Other Functions

- Rich choice of functions (e.g. counter, graphs, calculation results)

■ Operating Environment

- Connection interface: USB2.0
- PC: DOS/V compatible machine
- CPU: 2GHz or more (recommended)
- OS/software: WindowsXP, Excel2000XP Japanese version
- Memory: 256MB or more (recommended)
- Applicable display unit: LSM-5200

SystemDiagram Example of concurrent multi-point measurement of printer rollers

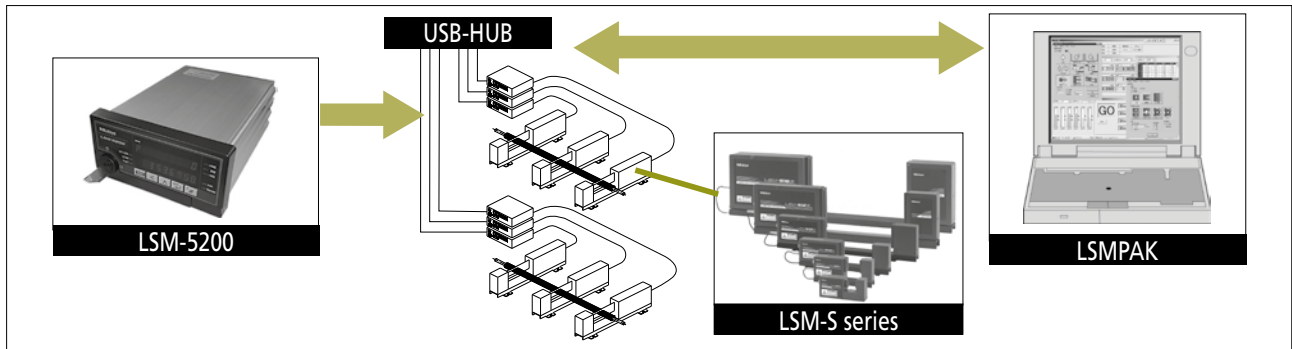

BCD Interface Unit (02AGC910)

- Outputs a 7-digit BCD and a positive or negative sign.
- Switchable data logic.
- The input and output circuits are isolated.

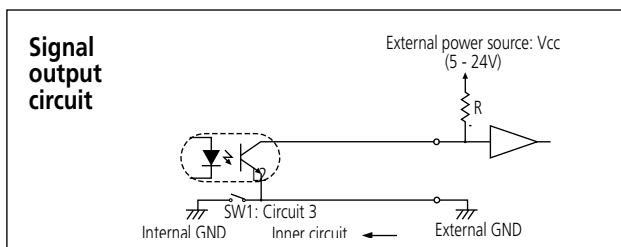
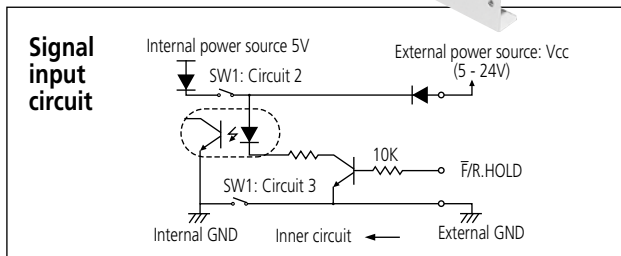
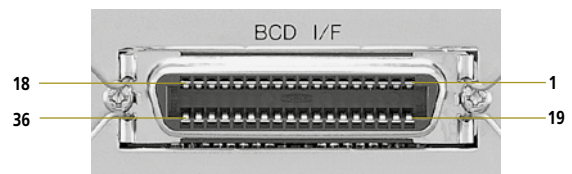
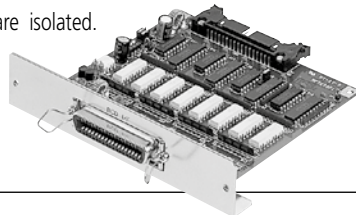

Pin assignment of BCD Interface Unit

Pin No.	Signal name	Pin No.	Signal name	Pin No.	Signal name
1	1 x 10 ⁰	15	4 x 10 ³	29	Err.0 (Segment error)
2	2 x 10 ⁰	16	8 x 10 ³	30	HOLD (input)
3	4 x 10 ⁰	17	1 x 10 ⁴	31	F/R
4	8 x 10 ⁰	18	2 x 10 ⁴	32	STB (Strobe output)
5	1 x 10 ¹	19	4 x 10 ⁴	33	EXT.Vcc (Ext. power)
6	2 x 10 ¹	20	8 x 10 ⁴	34	+POLE (Polarity)
7	4 x 10 ¹	21	1 x 10 ⁵	35	GND (Signal GND)
8	8 x 10 ¹	22	2 x 10 ⁵	36	FG (Frame GND)
9	1 x 10 ²	23	4 x 10 ⁵		
10	2 x 10 ²	24	8 x 10 ⁵		
11	4 x 10 ²	25	1 x 10 ⁶		
12	8 x 10 ²	26	2 x 10 ⁶		
13	1 x 10 ³	27	4 x 10 ⁶		
14	2 x 10 ³	28	8 x 10 ⁶		

Applicable connector: 57-40360-D (Standard accessory)

Digimatic Code-out Unit (02AGC840)

- Provides two channels of SPC (Digimatic) output.
- Outputs the following during simultaneous measurement: From OUTPUT1: Measured values by PRG.0 through PRG.4. From OUTPUT2: Measured values by PRG.5 through PRG.9
- The output cable (936937) is optional.

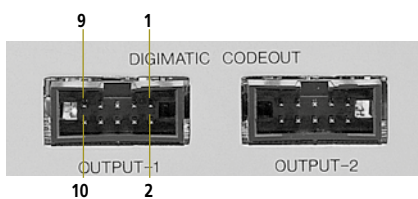
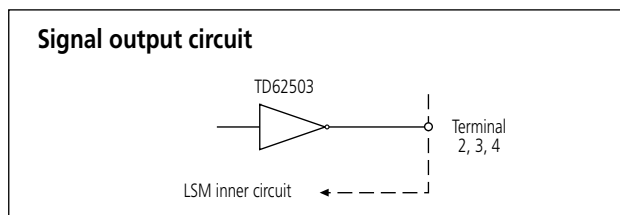
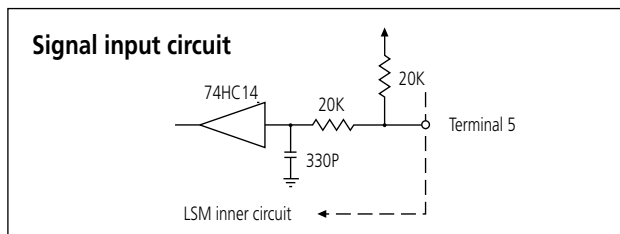

Pin assignment of Digimatic Code-out Unit

Pin No.	Signal name	I/O	Function
1	GND	—	Signal GND
2	DATA	OUT	Data out
3	\overline{CK}	OUT	Data transmission clock
4	\overline{RD}	OUT	Data read request
5	REQ	IN	Data output request
6, 7, 8, 9	I.C	—	Spare
10	F.G	—	Frame GND

*Not available for LSM-6900

Dual-type Add-on Unit (02AGP150)*

- Enables a second measuring unit to be connected to the display unit (this is possible only if the two measuring units are the same model).
- Depending on the layout of the two measuring units, large-diameter measurement, XY measurement, and parallel measurement are possible.
- The sub-display of the LSM-6200 allows simultaneous measurement and display with two measuring units.

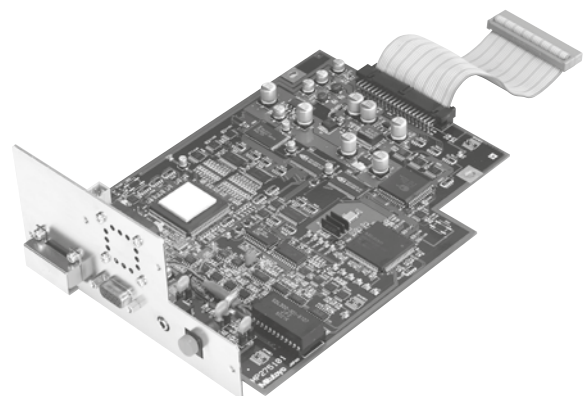

Large-diameter measurement

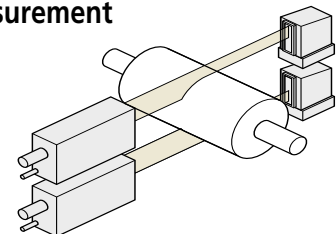

XY measurement

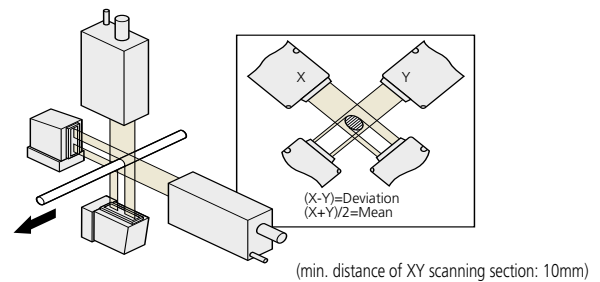

Parallel measurement

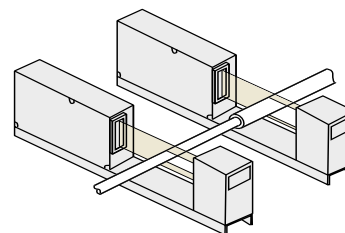

Optional accessories

2nd I/O-Analog Interface Unit (02AGC880)

- Provides I/O capability and analog voltage output for GO/±NG judgment.
- Provides two sets of GO/NG judgment result outputs. Fully compatible with simultaneous measurement, since measurement values from PRG.5 through PRG.9 will be output as analog signals.

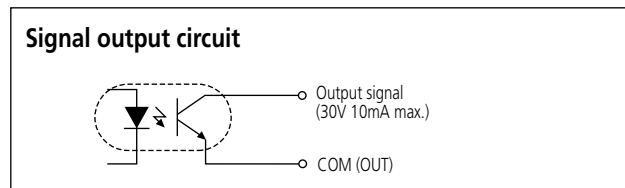
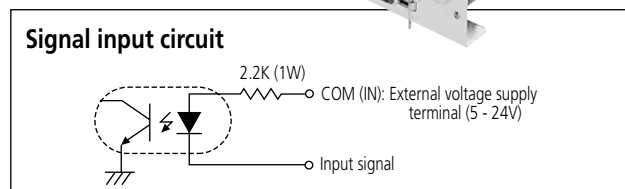
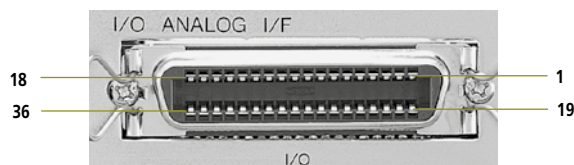
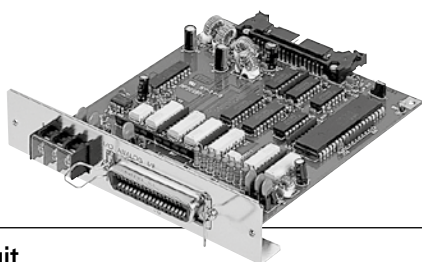

Pin assignment of 2nd I/O-Analog Interface Unit

Pin No.	Signal name	I/O
1	+5V	(Internal power)
2	COM (IN)	(IN)
3	PROG.0/b0	IN
4	PROG.2/b2	IN
5	PROG.4/PRG	IN
6	SHIFT	IN
7	RUN	IN
8	\bar{A} (-NG)	OUT
9	I.C	(OUT)
10	I.C	(OUT)
11	\bar{B} (-NG)	OUT
12	\bar{B} (+NG)	OUT
13	I.C	(OUT)
14	\bar{A} (+NG)	OUT
15	\bar{A} (GO)	OUT
16	ERR.0	OUT
17	COM (OUT)	(OUT)
18	\bar{C} NT	OUT
19	GND	(Internal power)
20	COM (IN)	(IN)
21	PROG.1/b1	IN
22	PROG.3/b3	IN
23	I.C	(OUT)
24	PRINT	IN
25	RESET	IN
26	\bar{A} (GO)	OUT
27	I.C	(OUT)
28	I.C	(OUT)
29	\bar{B} (GO)	OUT
30	I.C	OUT
31	I.C	(OUT)
32	\bar{A} (-NG)	OUT
33	ACK	OUT
34	STB	OUT
35	COM (OUT)	(OUT)
36	FG	—

With a combined use of b0, b2, PRG, b1 and b3 maximum 100 patterns of program can be used.

System Extension Devices

Extension Cable for Concurrent Installation of BCD and Second I/O-Analog Interface

No.02AGE060

- The use of this cable enables concurrent installation of BCD (No.**02AGC910**) and second I/O-Analog interface (No.**02AGC880**) in LSM-6200/6900.

*Restrictions

If this cable is used, the dual extension unit (No.**02AGP150**) is not available.

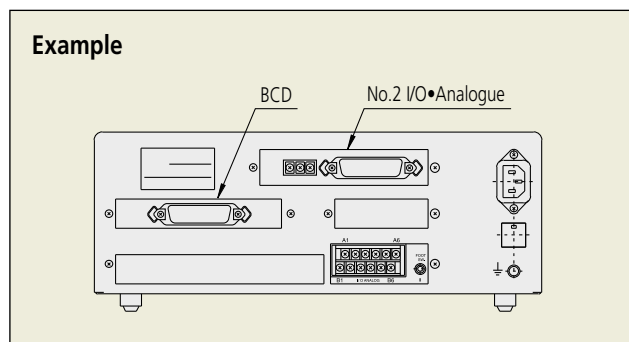
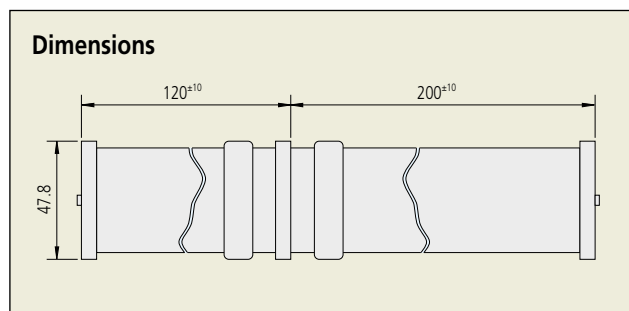

Thermal Printer

- This printer can be connected to any LSM-5100, -6200, -6900 or -9506 model.
- Both measurement values and statistical calculation results can be printed (only with LSM-6200/6900/9506).
- Connection cable is supplied.



Order No.	02AGD600A (w/100V AC adapter) 02AGD600B (w/120V AC adapter) 02AGD600C (w/130V AC adapter)
Type	Thermal serial-dot printer
Digits per line	40
Character format	9x8 dot matrix
Data input	Via RS-232C interface
Printer life	500,000 lines
Operational temperature range	0°C to 50°C
Power supply	Via AC adapter (100V AC, 50/60Hz)
Standard accessories	Printer paper (1 roll), AC adapter
Consumable item	Printer paper set (10-roll, 223663)

Footswitch (937179T)*

- Connecting the Footswitch to the LSM-6100/6900/9506 enables the user to initiate a single measurement externally.



Glossary

1. Linearity

This is a specified value that defines the maximum error* that may be indicated by the LSM after calibration**, anywhere within its measuring range, when measuring a workpiece in the center of the measuring region. Note that the linearity specification does not include the calibration error specification of the calibration gages themselves. This error must be added separately.

- * The difference between the result of measuring a dimension and the true value of the dimension measured.
- ** Optional calibration gages are available for each model of LSM to provide appropriate high and low calibration points (HiCAL and LoCAL on the diagram).

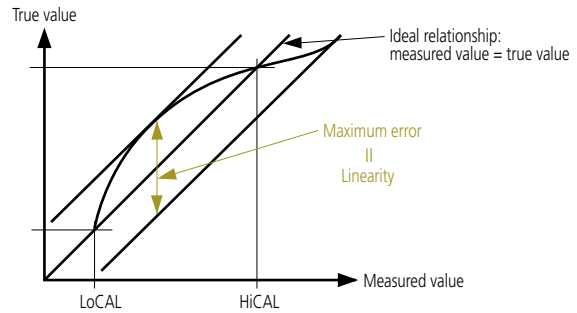

2. Repeatability

Means, in the center of a measuring region, the dispersion ($\pm 2\sigma$) of measurement values as the result of continuous measurement for 2 minutes with the number of scans for averaging set at 512 times (1024 times for LSM-902/6900) without moving a workpiece of the maximum measurement diameter on each measuring unit.

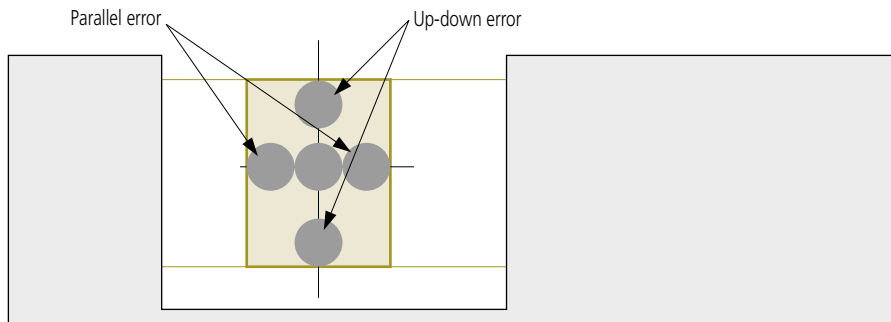

3. Position error

Means an error with reference to the measurement value at the center of the measuring region if a workpiece is displaced in the measuring region. A position error consists of an up-down error and a parallel error as shown in the following figure. This error separately affects measurement accuracy.

4. Measuring region

The LSM provides numeric values for which the accuracy (linearity + position error) is guaranteed only if a workpiece is located within the prescribed space domain. This domain is called the measuring region. A measuring region is determined by [laser beam scanning direction range] x [optical axis direction range]. To perform measurement with a minimum of error, it is necessary to measure a workpiece at the center of this measuring region. As an example in the figure right, workpieces 1, 2, 5, and 6 cannot be measured because these are outside the measuring region. For workpieces 3 and 4, a position error is added to a linearity error.

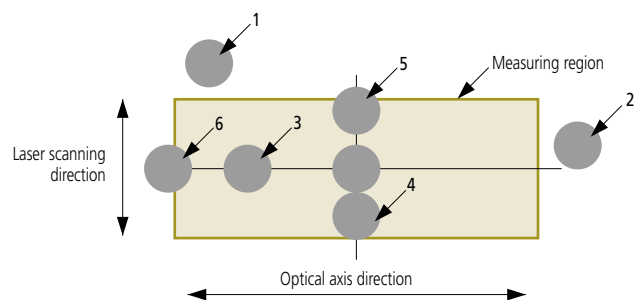

5. Beam diameter and width

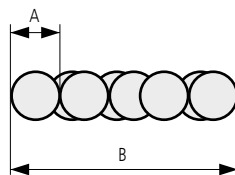

	LSM-902/6900	LSM-500S	LSM-501S	LSM-503S	LSM-506S	LSM-9506	LSM-512S	LSM-516S
Beam diameter A	200 μ m	80 μ m	120 μ m	240 μ m	600 μ m	600 μ m	1200 μ m	1200 μ m
Beam diameter B	300 μ m	120 μ m	170 μ m	340 μ m	800 μ m	800 μ m	1600 μ m	1600 μ m

Precautions

Observe the following precautions

Compatibility

Your Laser Scan Micrometer has been adjusted together with the ID Unit, which is supplied with the measuring unit. The ID Unit, which has the same code number and the same serial number as the measuring unit, must be installed in the display unit. This means that if the ID Unit is replaced the measuring unit can be connected to another corresponding display unit.

The workpiece and measuring conditions

Depending on whether the laser is visible or invisible, the workpiece shape, and the surface roughness, measurement errors may result. If this is the case, perform calibration with a master workpiece which has dimensions, shape, and surface roughness similar to the actual workpiece to be measured. If measurement values show a large degree of dispersion due to the measuring conditions, increase the number of scans for averaging to improve the measurement accuracy.

Electrical interference

To avoid operational errors, do not route the signal cable and relay cable of the Laser Scan Micrometer alongside a high-voltage line or other cable capable of inducing noise current in nearby conductors. Ground all appropriate units and cable shields.

Connection to a computer

If the Laser Scan Micrometer is to be connected to an external personal computer via the RS-232C interface, ensure that the cable connections conform to the specification.

Laser safety

Mitutoyo Laser Scan Micrometers use a low-power visible laser for measurement. The laser is a CLASS 2 IEC 825-1 device and a CLASS II 21 CDRH device. Warning and explanation labels, as shown right, are attached to the Laser Scan Micrometers as is appropriate.

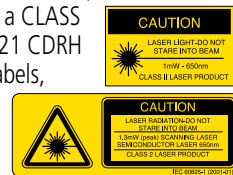

Re-assembly after removal from the base

Observe the following limits when re-assembling the emission unit and reception unit to minimize measurement errors due to misalignment of the laser's optical axis with the reception unit.

(1) Alignment within the horizontal plane

a. Parallel deviation between reference lines C and D: X (in the transverse direction)

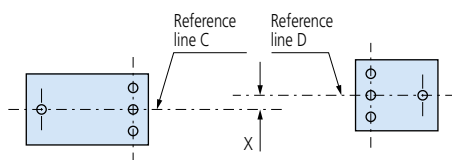

b. Angle between reference lines C and D: θ_x (angle)

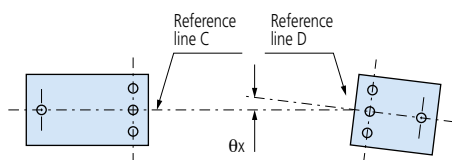

(2) Alignment within the vertical plane

c. Parallel deviation between reference planes A and B: Y (in height)

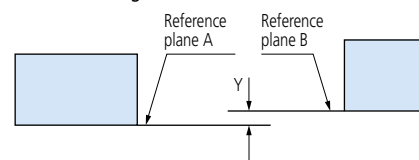

d. Angle between reference planes A and B: θ_y (angle)

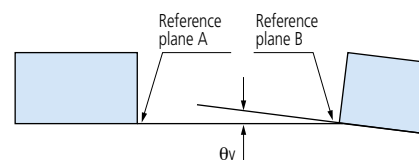

(3) Allowable limits of optical axis misalignment

Model	Distance between Emission Unit and Reception Unit	X and Y	θ_x and θ_y
LSM-501S	68mm (2.68") or less	within 0.5mm (.02")	within 0.4° (7 mrad)
	100mm (3.94") or less	within 0.5mm (.02")	within 0.3° (5.2 mrad)
LSM-503S	130mm (5.12") or less	within 1mm (.04")	within 0.4° (7 mrad)
	350mm (13.78") or less	within 1mm (.04")	within 0.16° (2.8 mrad)
LSM-506S	273mm (10.75") or less	within 1mm (.04")	within 0.2° (3.5 mrad)
	700mm (27.56") or less	within 1mm (.04")	within 0.08° (1.4 mrad)
LSM-512S	321mm (12.64") or less	within 1mm (.04")	within 0.18° (3.6 mrad)
	700mm (27.56") or less	within 1mm (.04")	within 0.08° (1.4 mrad)
LSM-516S	800mm (31.50") or less	within 1mm (.04")	within 0.09° (1.6 mrad)



**Whatever your challenges are,
Mitutoyo supports you from start to finish.**

Mitutoyo is not only a manufacturer of top quality measuring products but one that also offers qualified support for the lifetime of the equipment, backed up by comprehensive services that ensure your staff can make the very best use of the investment.

Apart from the basics of calibration and repair, Mitutoyo offers product and metrology training, as well as IT support for the sophisticated software used in modern measuring technology. We can also design, build, test and deliver bespoke measuring solutions and even, if deemed cost-effective, take your critical measurement challenges in-house on a sub-contract basis.

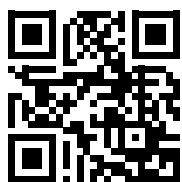

**Find additional product literature
and our product catalogue**

www.mitutoyo.eu

Note: Product illustrations are without obligation. Product descriptions, in particular any and all technical specifications, are only binding when explicitly agreed upon.
MITUTOYO and MiCAT are either registered trademarks or trademarks of Mitutoyo Corp. in Japan and/or other countries/regions.
Other product, company and brand names mentioned herein are for identification purposes only and may be the trademarks of their respective holders.

Mitutoyo

Mitutoyo Europe GmbH

Borsigstraße 8-10
41469 Neuss

Tel. +49 (0) 2137-102-0
Fax +49 (0) 2137-102-351

info@mitutoyo.eu
www.mitutoyo.eu